

Instruction Book

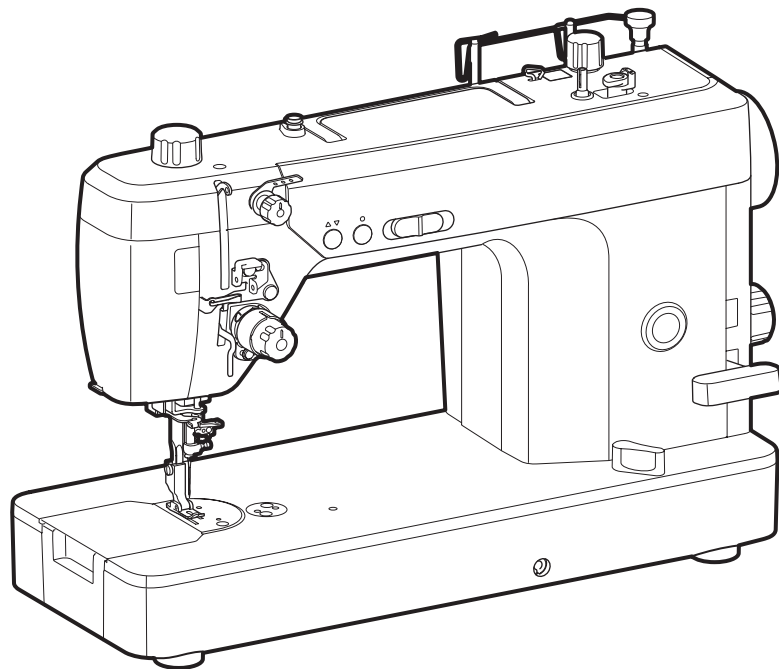

IMPORTANT SAFETY INSTRUCTIONS

When using an electrical appliance, basic safety precautions should always be followed, including the following:

This sewing machine is designed and manufactured for household use only.

Read all instructions before using this sewing machine.

DANGER— To reduce the risk of electric shock:

1. An appliance should never be left unattended when plugged in. Always unplug this sewing machine from the electric outlet immediately after using and before cleaning

WARNING— To reduce the risk of burns, fire, electric shock, or injury to persons:

1. Do not allow to be used as a toy. Close attention is necessary when this sewing machine is used by or near children.
2. Use this appliance only for its intended use as described in this owner's manual. Use only attachments recommended by the manufacturer as contained in this owner's manual.
3. Never operate this sewing machine if it has a damaged cord or plug, if it is not working properly, if it has been dropped or damaged, or dropped into water. Return this sewing machine to the nearest authorized dealer or service center for examination, repair, electrical or mechanical adjustment.
4. Never operate the appliance with any air opening blocked. Keep ventilation openings of this sewing machine and foot controller free from accumulation of lint, dust and loose cloth.
5. Never drop or insert any object into any opening.
6. Do not use outdoors.
7. Do not operate where aerosol (spray) products are being used or where oxygen is being administered.
8. To disconnect, turn all controls to the OFF ("O") position, then remove plug from outlet.
9. Do not unplug by pulling on cord. To unplug, grasp the plug, not the cord.
10. Keep fingers away from all moving parts. Special care is required around the sewing machine needle and/or cutting blade.
11. Always use the proper needle plate. The wrong plate can cause the needle to break.
12. Do not use bent needles.
13. Do not pull or push fabric while stitching. It may deflect the needle causing it to break.
14. Switch this sewing machine OFF ("O") when making any adjustment in the needle area, such as threading the needle, changing the needle, threading the bobbin or changing the presser foot, and the like.
15. Always unplug this sewing machine from the electrical outlet when removing covers, lubricating, or when making any other adjustments mentioned in this owner's manual.

SAVE THESE INSTRUCTIONS

For Europe only:

This appliance can be used by children aged from 8 years and above and persons with reduced physical, sensory or mental capabilities or lack of experience and knowledge if they have been given supervision or instruction concerning use of the appliance in a safe way and understand the hazards involved. Children shall not play with the appliance. Cleaning and user maintenance shall not be made by children without supervision.

For outside Europe (except U.S.A.):

This appliance is not intended for use by persons (including children) with reduced physical, sensory or mental capabilities, or lack of experience and knowledge, unless they have been given supervision or instruction concerning use of the appliance by a person responsible for their safety.

Children should be supervised to ensure that they do not play with the appliance.



Please note that on disposal, this product must be safely recycled in accordance with relevant National legislation relating to electrical/electronic products. If in doubt please contact your retailer for guidance. (EEA (European Economic Area) and UK)

TABLE OF CONTENTS

ESSENTIAL PARTS

Part Names.....	2
Standard Accessories.....	3
Knee Lifter	4
Attaching the Extra Wide Table	4

GETTING READY TO SEW

Connecting Machine to Power Supply.....	5
Before Using Your Sewing Machine	5
Controlling Sewing Speed	5
Needle up/down button.....	6
Bobbin Winding Button.....	6
Thread Cutter Button	6
Stitch Length Adjustment Dial.....	6
Reverse Stitch Lever	6
Presser Foot Lifter	7
Foot Pressure Dial.....	7
Dropping or Raising the Feed Dogs	7
Attaching and Detaching Presser Foot.....	8
Sewing Light Brightness	8
To Remove Bobbin Case and Bobbin.....	9
Setting a Spool of Thread.....	9
Winding a Bobbin	10
Inserting a Bobbin.....	11
Inserting the Bobbin Case into the Hook.....	11
Threading the Needle Thread (for Leather, Heavy Fabric)	12
Adjusting the needle thread tension by the thread guide.....	13
Threading the Needle Thread (for medium and light fabric).....	14
Threading guide sticker	15
Built-in Needle Threader.....	16
Drawing up the Bobbin Thread.....	17
Changing the Needle.....	18
To check the needle	18
Thread and Needle Chart.....	18
Balancing Needle Thread Tension.....	19
Adjusting Bobbin Thread Tension.....	19
Adjusting Needle Thread Tension.....	19

HOW TO SEW

Test Stitching	20
Securing a Seam.....	21
By reverse stitching.....	21
By knotting the threads	21
Turning a Square Corner.....	21
Floating Dial.....	22
Using the Cloth Guide	23
Rolled Hem.....	23
Free motion quilting.....	24
Attaching the free motion quilting foot holder	24
Changing the foot	24
Adjusting the height of the foot.....	24
Quilt Piecing	25
Ditch Quilting	25

CARE & MAINTENANCE

Cleaning the Hook and Feed Dogs	26
Oiling the Machine.....	26
Troubleshooting.....	27

ESSENTIAL PARTS

Part Names

- (1) Foot pressure dial
- (2) Oiling hole
- (3) Bobbin winding tension disk
- (4) Thread guide A
- (5) Presser foot height indicator
- (6) Floating dial
- (7) Retractable thread guide
- (8) Bobbin winder spindle
- (9) Bobbin winder stopper
- (10) Speed control slider
- (11) Stitch length display
- (12) Thread cutter button
- (13) Reverse stitch lever
- (14) Drop feed lever
- (15) Bobbin winding button
- (16) Needle up/down button
- (17) Knee lifter socket
- (18) Pre-tension dial
- (19) Thread guide C
- (20) Tension dial
- (21) Thread guide B
- (22) Hook cover
- (23) Hook cover plate
- (24) Needle plate
- (25) Thread cutter
- (26) Face cover
- (27) Thread guide D
- (28) Foot pressure indicator
- (29) Thread take-up lever
- (30) Needle threader
- (31) Thread guide E
- (32) Needle clamp screw
- (33) Needle
- (34) Holes for attachments
- (35) Presser foot
- (36) Feed dogs
- (37) Setscrew
- (38) Carrying handle
- (39) Presser foot lifter
- (40) Spool pins
- (41) Ventilation openings
- (42) Machine socket
- (43) Foot control jack
- (44) Thread cutter switch jack* (2.5 mm jack)
- (45) Power switch
- (46) Stitch length adjustment dial
- (47) Handwheel
- (48) Foot control
- (49) Power supply cord**

*Thread cutter switch is an optional item.

**The power supply cable included may differ from the illustration.

NOTE:

- To carry the sewing machine, hold the carrying handle with your hand, and support the sewing machine with the other hand.
- Designs and specifications are subject to change without prior notice.

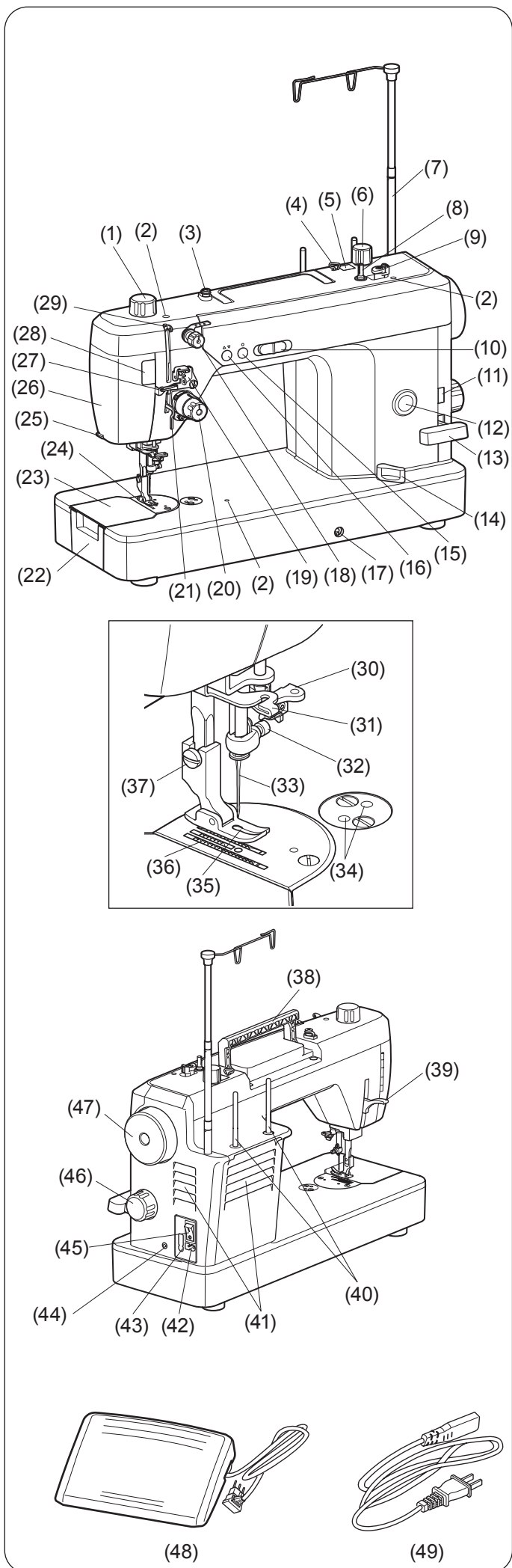

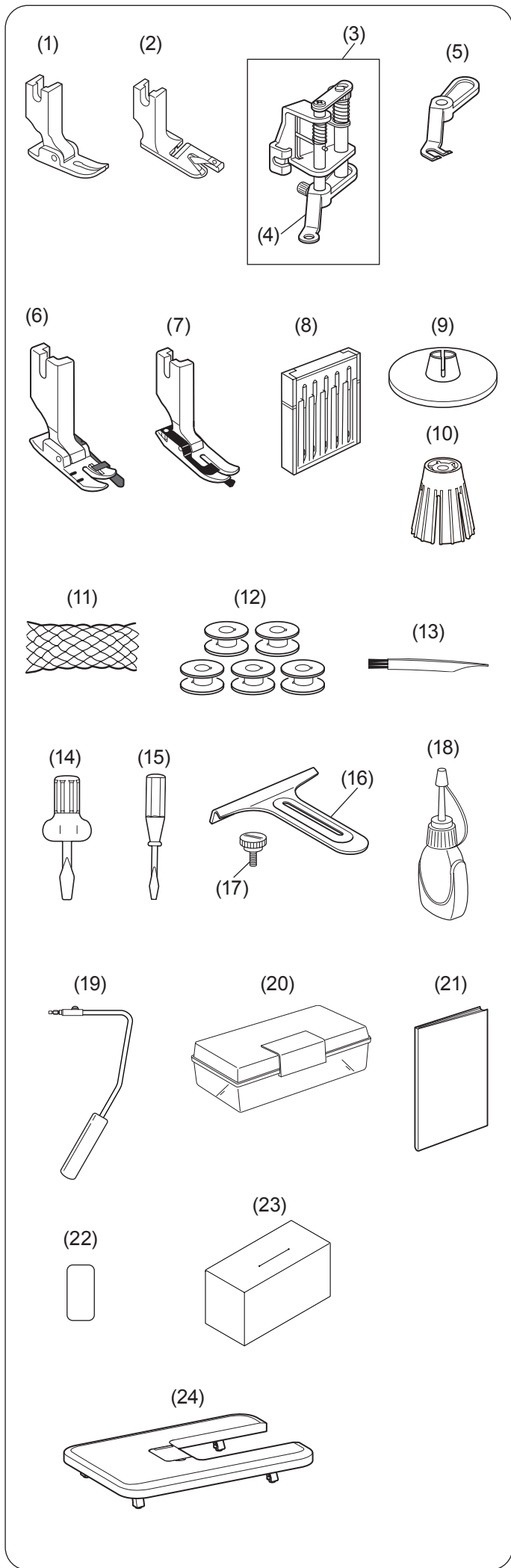

Standard Accessories

No.	Part Name	Part No.
1	Standard foot (set on the machine)	762505003
2	Hemmer foot	761172004
3	Free motion quilting foot holder	767433129
4	Closed-toe foot	202002303
5	Open-toe foot	202002406
6	Quilting foot	767820002
7	Ditch quilting foot	767824006
8	Needle set (HL x 5 -14)	767859000
9	Spool cap	822020503
10	Spool holder	784223105
11	Net	624806006
12	Bobbin x 5 (1 is set on the machine)	767860107*
13	Lint brush	802424004
14	Screwdriver (large)	820832005
15	Screwdriver (small)	647803004
16	Cloth guide	200100801
17	Thumbscrew	825252000
18	Oil	770816201
19	Knee lifter	846417011
20	Accessory box	366401400
21	Instruction book	768800009
22	Threading guide sticker	101631A01
23	Cover	767805609
24	Extra wide table	499702915

*This is the part number of a single item (not for a set).

Knee Lifter

The knee lifter is extremely helpful when sewing patchwork, quilting etc., since it allows you to handle the fabric while your knee controls the presser foot.

CAUTION:

In the following cases, moving the knee lifter too high may cause the presser foot to hit the needle bar, leading to malfunction or damage:

- When changing the sewing direction while the needle is down.
- When pressing the needle up/down button while the presser foot is raised by the knee lifter.
- When turning the handwheel while the presser foot is raised by the knee lifter.

Attaching the knee lifter

Match the ribs on the knee lifter with the notches in the knee lifter socket and insert the knee lifter.

- (1) Knee lifter
- (2) Knee lifter socket

Adjusting the knee lifter

The angle of the knee lifter can be adjusted to fit your knee position.

Loosen the setscrew and slide the angle bar in or out to adjust the angle of the knee lifter.

Tighten the setscrew to secure the angle bar.

- (3) Setscrew
- (4) Angle bar

Using the knee lifter

Push the knee lifter to the right with your knee to easily move the presser foot up.

You can control how high the foot rises by the amount you move the knee lifter.

NOTE:

Do not touch the knee lifter while stitching, otherwise the fabric will not be fed smoothly.

Attaching the Extra Wide Table

Raise the table legs (4 places) and set them from above so that they fit into the sewing machine body.

Adjust the setscrews on the table legs (4 places) with a Phillips screwdriver so that the table height is the same as the sewing machine body.

- (1) Leg
- (2) Setscrew

NOTE:

A Phillips screwdriver is not included as standard accessories.

⚠ WARNING:

- While in operation, always keep your eyes on the sewing area, and do not touch any moving parts such as the thread take-up lever, handwheel or needle.
- Always turn off the power switch and unplug the machine from the power supply:
 - when leaving the machine unattended.
 - when attaching or removing parts.
 - when cleaning the machine.
- Do not place anything on the foot control.

NOTE:

- Make sure to use the power supply cable that came with the machine.

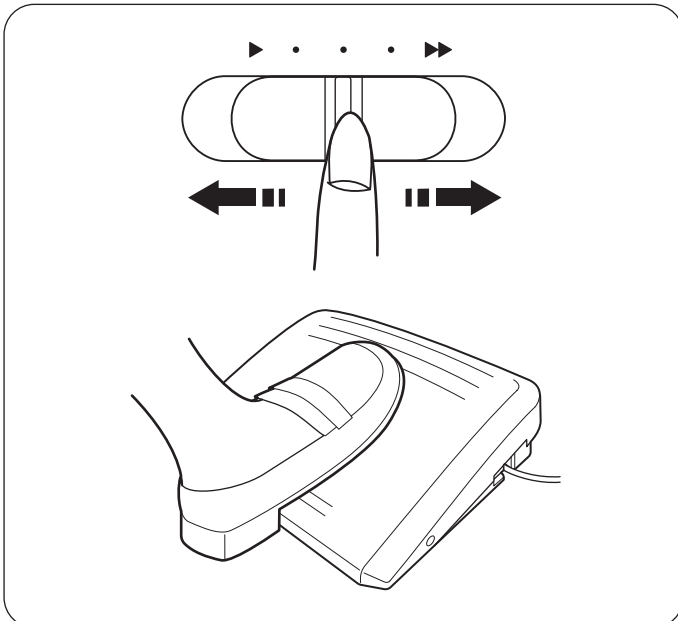
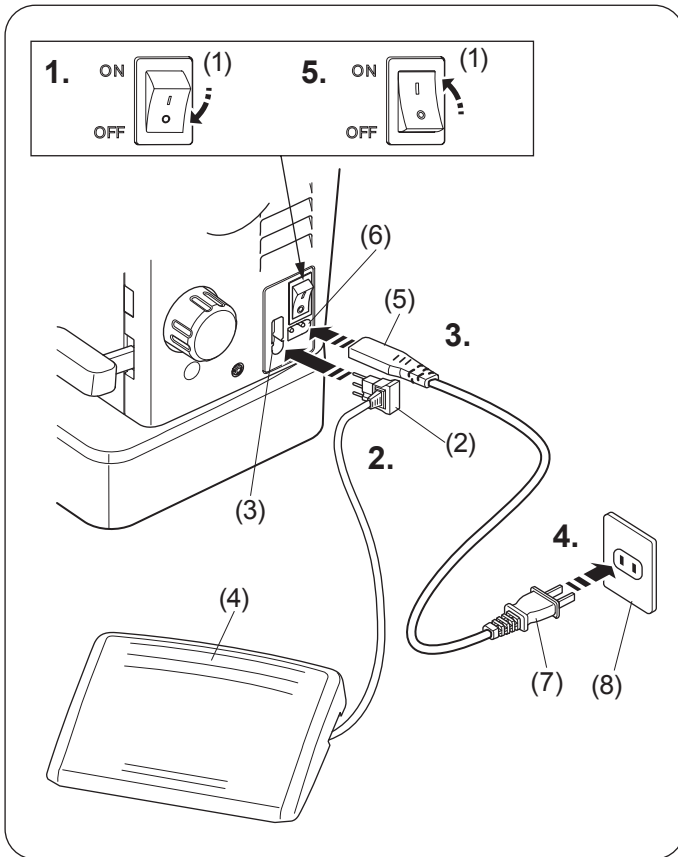

GETTING READY TO SEW

Connecting Machine to Power Supply

⚠ CAUTION:

Always turn the power switch OFF and unplug the sewing machine from the electrical outlet when the machine is not in use.

NOTE:

Depending on the model, the machine will turn OFF if you do not use the machine within 7 hours.

1. Turn the power switch OFF.
 - (1) Power switch
2. Insert the foot control plug into the foot control jack.
 - (2) Foot control plug
 - (3) Foot control jack
 - (4) Foot control
3. Insert the machine plug into the machine socket.
 - (5) Machine plug
 - (6) Machine socket
4. Insert the power supply plug into the power outlet.
 - (7) Power supply plug
 - (8) Power outlet
5. Turn the power switch ON.

Before Using Your Sewing Machine

Before using your sewing machine for the first time, place a scrap of fabric under the presser foot and run the machine for a few minutes.

Wipe away any oil which may appear.

Operating Instructions:

The symbol "O" on the power switch indicates the "OFF" position.

For the U.S.A. and Canada only

Polarized plug (one blade wider than the other):
To reduce the risk of electric shock, this plug is intended to fit in a polarized outlet only one way. If it does not fit fully in the outlet, reverse the plug. If it still does not fit, contact a qualified electrician to install the proper outlet. Do not modify the plug in any way.

Controlling Sewing Speed

Speed control slider

Sewing speed can be varied with the speed control slider according to your sewing needs.

To increase sewing speed, slide it to the right.

To decrease sewing speed, slide it to the left.

Foot control

Sewing speed is varied by the foot control.

The further you press down on the foot control, the faster the machine runs.

The machine runs at the maximum speed set by the speed control slider when the foot control is fully depressed.

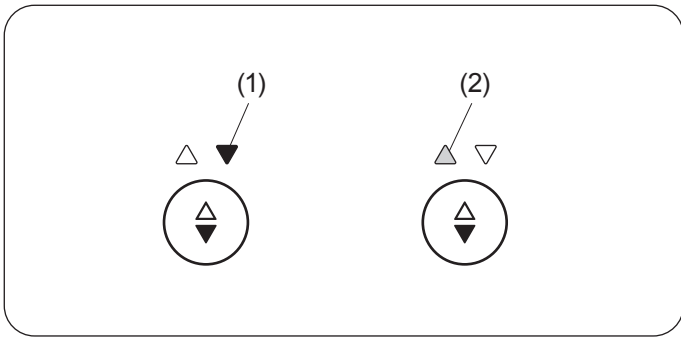

Needle up/down button

Press this button to move the needle bar up or down. The red LED light will light up when the needle is down. The blue LED light will light up when the needle is up. The machine will stop with the needle up or down depending on the needle position determined by this button.

- (1) Red LED light
- (2) Blue LED light

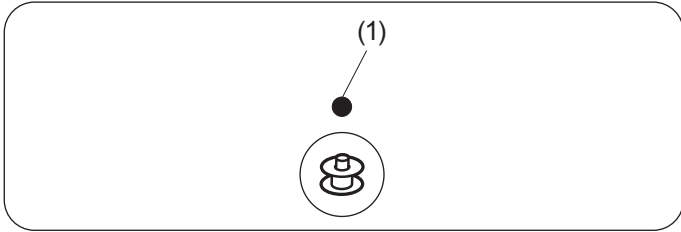

Bobbin Winding Button

Press this button to wind the bobbin. The LED light will light up when you shift the bobbin winding stopper toward the bobbin and press this button. The LED light will turn OFF after bobbin winding is finished.

- (1) LED light

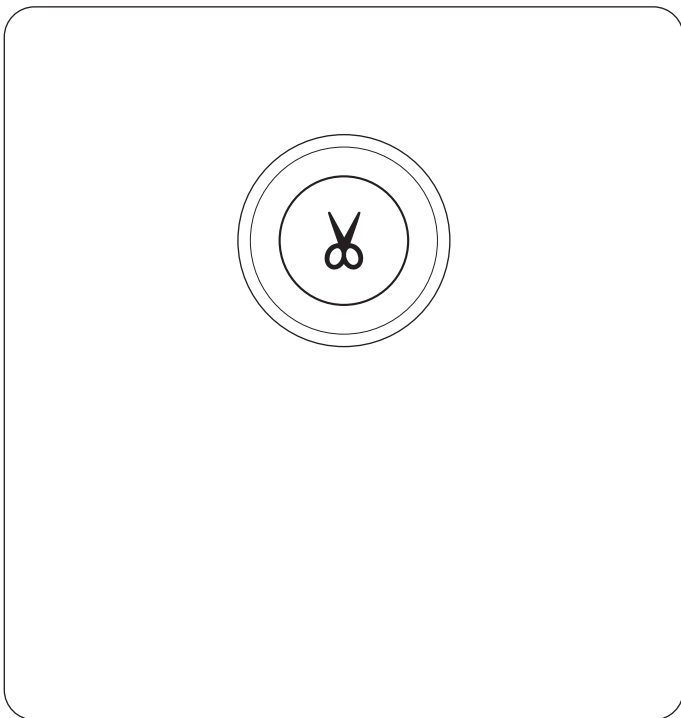

Thread Cutter Button

Pressing this button after sewing will trim the threads. Next time you sew, you can continue sewing without having to pull up the bobbin thread. The machine will always stop with the needle up after auto thread cutting.

NOTE

- The thread cutter button cannot be used in the following cases:
 - Immediately after turning ON the power switch.
 - When the presser foot is raised.
 - When the thread cutter button is pressed three times or more in succession.
- Use the thread cutter on the face cover if the thread is thicker than #30 (refer to page 20).
- The foot control and needle up/down button cannot be used while the machine is trimming the threads.
- The thread cutter switch (optional item) can also be used.

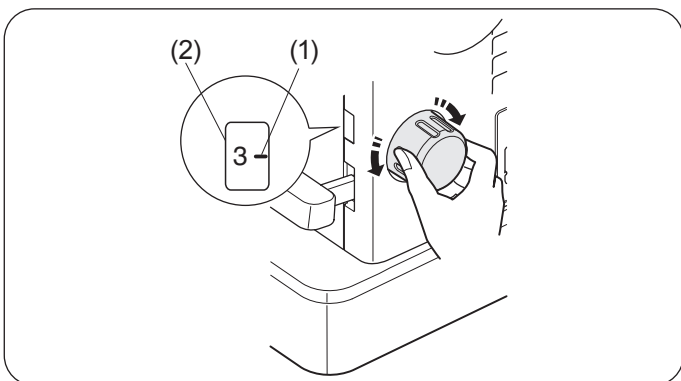

Stitch Length Adjustment Dial

You can adjust the stitch length from 0 to 6 mm by turning this dial. Adjust the stitch length by aligning the number with the mark on the stitch length display.

- (1) Mark
- (2) Stitch length display

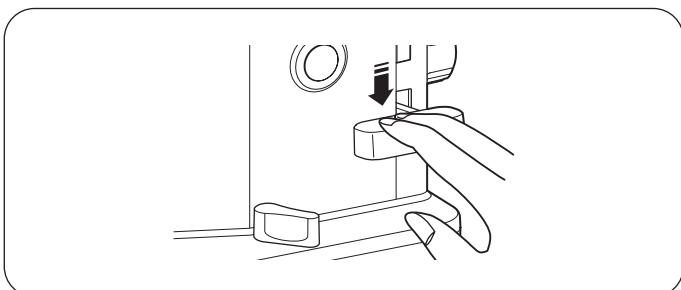

Reverse Stitch Lever

The machine will sew in reverse while the reverse stitch lever is pressed down. The machine will sew forward if the lever is released. Use the lever to lock the beginning and end of seams.

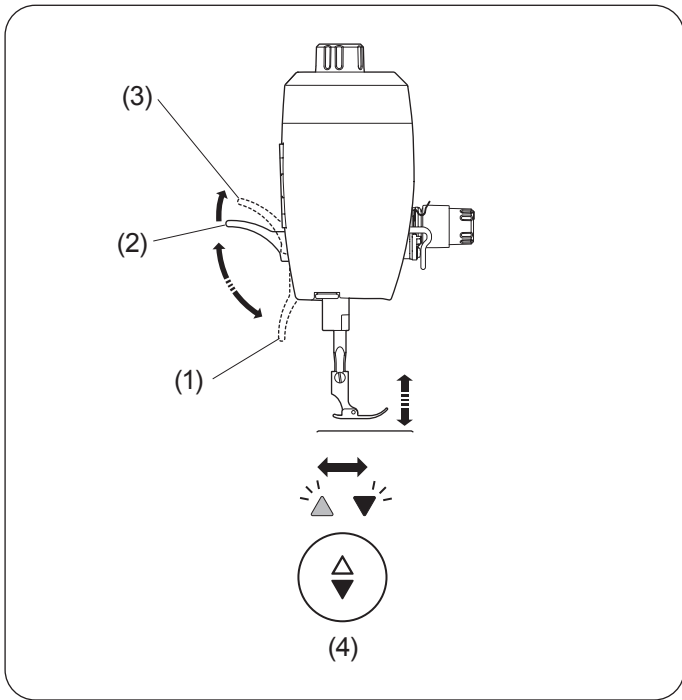

Presser Foot Lifter

⚠ CAUTION:

Do not turn the handwheel or press the needle up/down button when the presser foot is in extra lifted position. This may cause damage to the presser foot.

The presser foot lifter or the knee lifter raises and lowers the presser foot.

You can raise the presser foot about 6 mm (1/4") higher than the normal up position by exerting more pressure when lifting the presser foot lifter or knee lifter. This helps you to place layers of thick fabric.

- (1) Presser foot lifter
- (2) Normal up position
- (3) Extra lifted position

NOTE:

The machine will not run if the presser foot is in the up position. At this time, the LED lights on the needle up/down button will flash alternately.

- (4) Needle up/down button

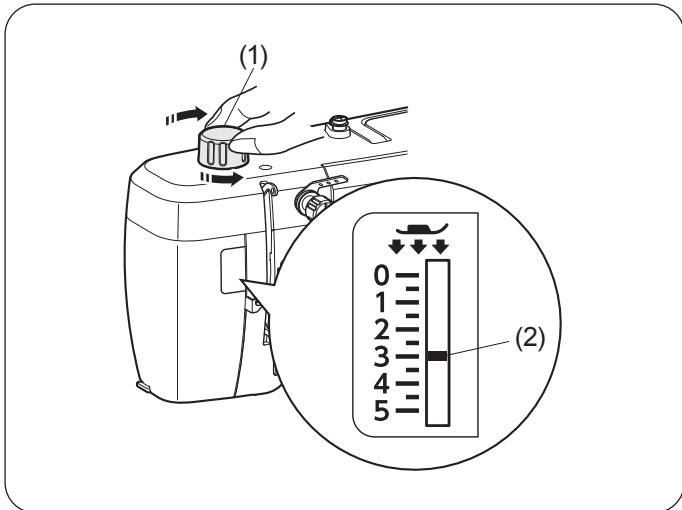

Foot Pressure Dial

The foot pressure dial should be set to "3" for regular sewing.

Reduce the pressure for appliqué, and for sewing on fine synthetics and elastic fabrics.

Set the dial to "1" when sewing extra fine fabrics.

- (1) Foot pressure dial
- (2) Setting indicator

NOTE:

Do not reduce the foot pressure lower than "0".

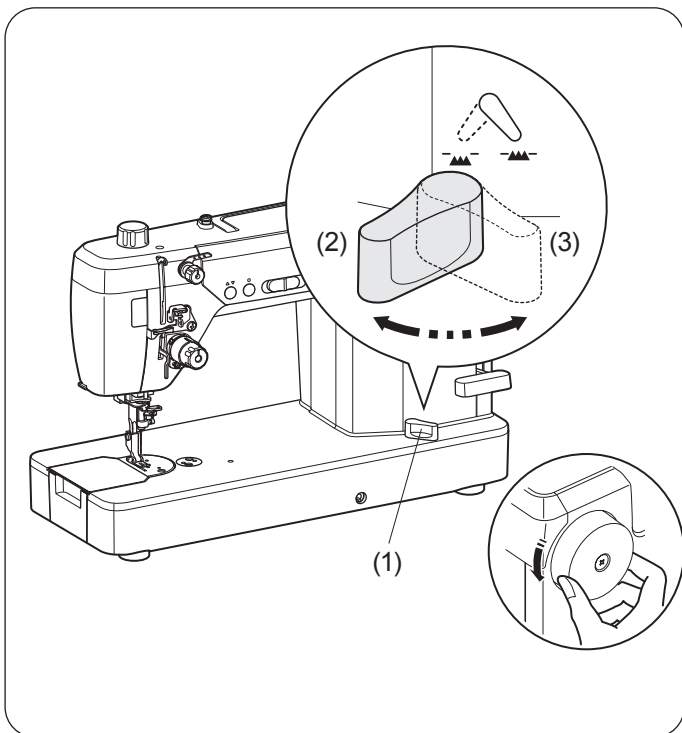

Droping or Raising the Feed Dogs

The feed dogs can be dropped for free motion quilting, etc.

The drop feed lever is located on the front of the machine.

- (1) Drop feed lever

To drop the feed dogs, move the lever to the left.

To raise the feed dogs, move the lever to the right and turn the handwheel toward you.

The feed dogs must be up for normal sewing.

- (2) Drop feed lever (left position)
- (3) Drop feed lever (right position)

Attaching and Detaching Presser Foot

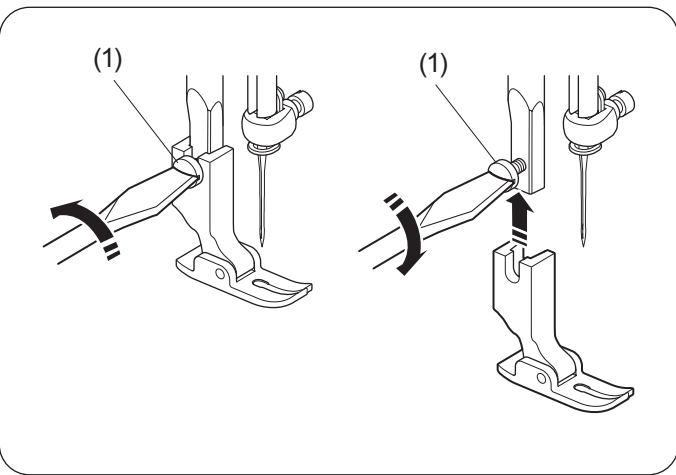

⚠ CAUTION:

Turn the power switch OFF and unplug the machine before changing the foot.

To change the presser foot, raise the presser foot lifter and needle.

Loosen the setscrew, choose the proper foot and insert it from below until the bottom of the groove touches the setscrew. Tighten the setscrew with the large screwdriver to secure the foot.

(1) Setscrew

Sewing Light Brightness

You can adjust the brightness of the sewing light.

1. Turn the power switch ON. Open the face cover.

(1) Face cover

2. Press the “+” key to increase the brightness of the sewing light.
Press and hold the “+” key to increase the brightness quickly.

(2) “+” key

Press the “-” key to decrease the brightness of the sewing light.

Press and hold the “-” key to decrease the brightness quickly.

(3) “-” key

3. After about one second, the sewing light flashes, and the brightness setting is registered.
Close the face cover.

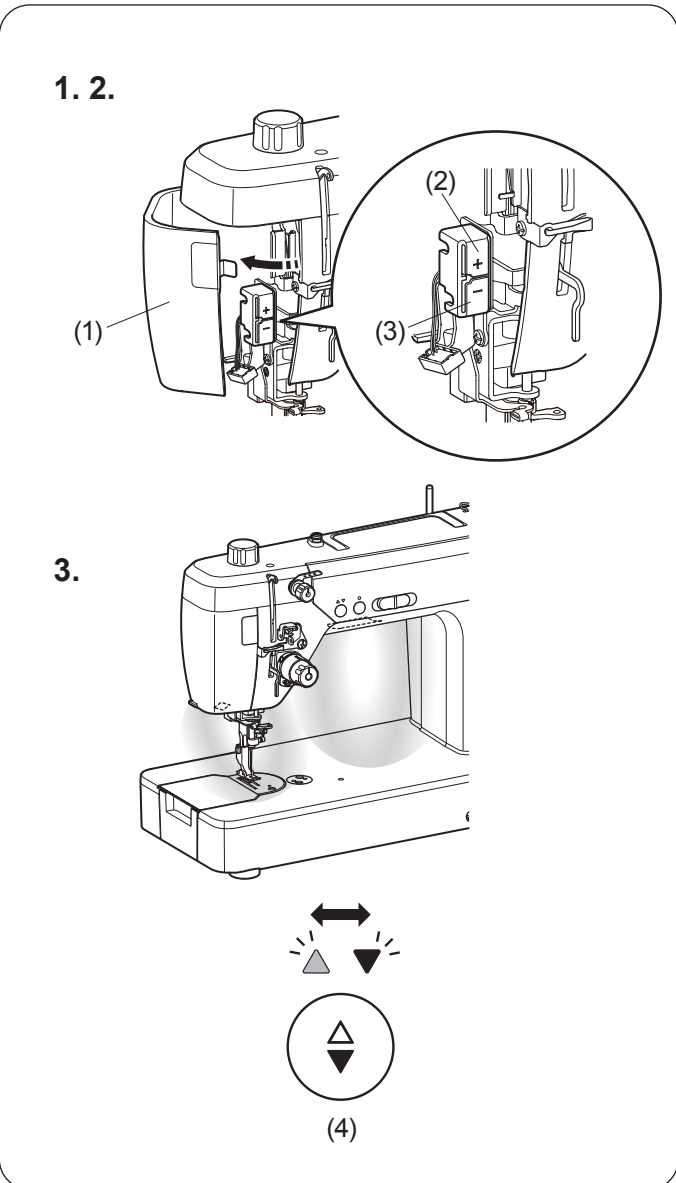

NOTE:

If you start sewing machine with the face cover open, needle up/down button LED lights will flash, and the machine will not operate.

(4) Needle up/down button

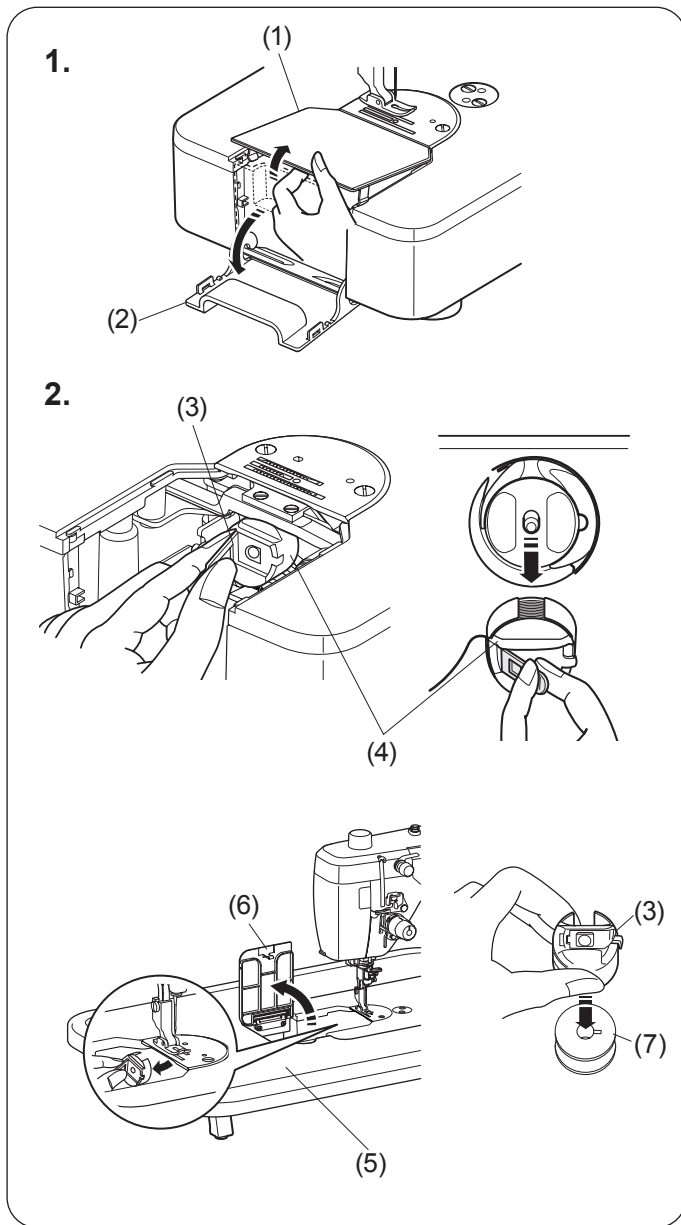

To Remove Bobbin Case and Bobbin

⚠ CAUTION:

Turn the power switch OFF and unplug the sewing machine from the electrical outlet

1. Raise the needle and presser foot.
Remove the hook cover plate and open the hook cover.
 - (1) Hook cover plate
 - (2) Hook cover
2. Pull open the latch of the bobbin case. Take the bobbin case straight out of the hook.
 - (3) Latch
 - (4) Bobbin case

When using the extra wide table

You can open the lid, remove the hook cover plate, and open the hook cover to remove the bobbin case without removing the extra wide table.

- (5) Extra wide table
- (6) Lid

To remove the bobbin from the bobbin case:

Release the latch, then drop the bobbin out of the bobbin case as illustrated.

- (3) Latch
- (7) Bobbin

NOTE:

Use a bobbin that came with the machine.

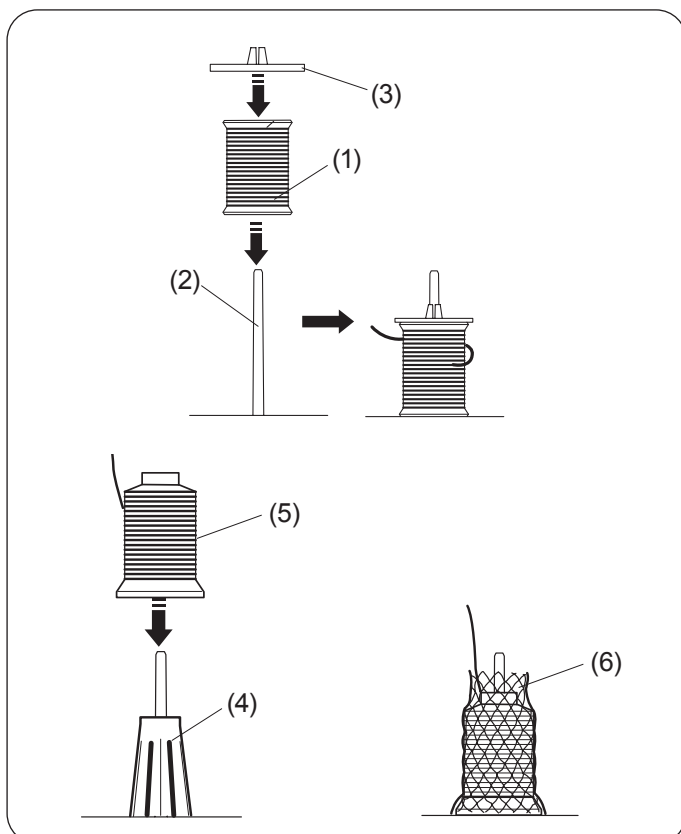

Setting a Spool of Thread

• Setting a spool of thread:

Place a spool of thread on the spool pin with the thread coming OFF the spool as shown. Attach the spool cap and press it firmly against the spool of thread.

- (1) Spool of thread
- (2) Spool pin
- (3) Spool cap

• Setting a thread cone:

Place the spool holder on the spool pin, then place the thread cone on the spool holder.

Cover the thread cone with the net if the spool thread is unstable when sewing.

- (4) Spool holder
- (5) Thread cone
- (6) Net

Winding a Bobbin

Pull the thread guide bar up as far as it will go.
Turn the thread guide bar until the stoppers click into position.

- (1) Thread guide bar
- (2) Stopper

1. Pass the thread through the guide on the thread guide bar from behind.
 - (3) Guide
2. Pass the thread through the thread guide A.
 - (4) Thread guide A
3. Hold the thread with both hands and pass the thread into the bobbin winding tension disk.
 - (5) Bobbin winding tension disk

4. Thread through the hole in the bobbin from the inside to the outside.
Match the notch with the spring on the bobbin winder spindle. Then insert the bobbin onto the bobbin winder spindle.

- (6) Bobbin hole
- (7) Notch
- (8) Spring
- (9) Bobbin winder spindle

5. Push the bobbin winder stopper to the left.
 - (10) Bobbin winder stopper

6. Hold the free end of the thread in your hand and press the bobbin winding button. Press the bobbin winding button again to stop the bobbin when it has made several turns, and cut the thread close to the hole in the bobbin.

- (11) Bobbin winding button

7. Press the bobbin winding button again. When the bobbin is fully wound, the machine will stop automatically. The bobbin winder stopper returns to its original position.
Cut the thread with scissors.
Remove the bobbin from the bobbin winder spindle.

NOTE:

This machine has an exclusive motor for bobbin winding, which allows you to wind a bobbin while stitching.

1.

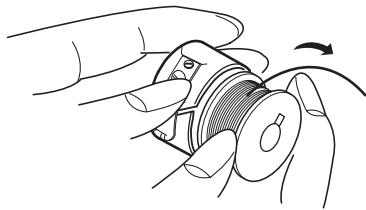

2.

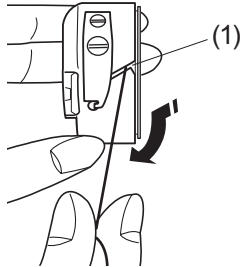

3.

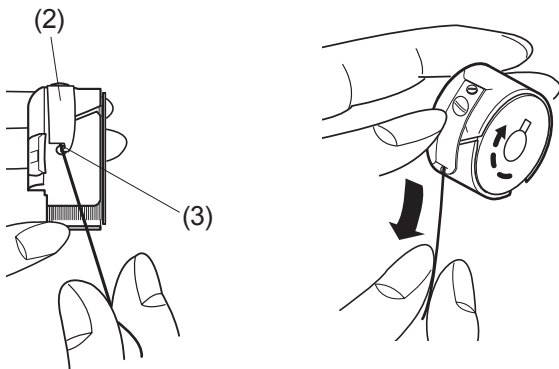

Inserting a Bobbin

1. Place a bobbin in the bobbin case making sure the thread winds clockwise on the bobbin as illustrated.
2. Draw the thread through the slit of the bobbin case.
 - (1) Slit
3. Continue to draw the thread under the tension spring and through the opening. Pull out about 4" (10 cm) of thread. The bobbin should spin clockwise when the thread is pulled out of the bobbin case.
 - (2) Tension spring
 - (3) Opening

1.

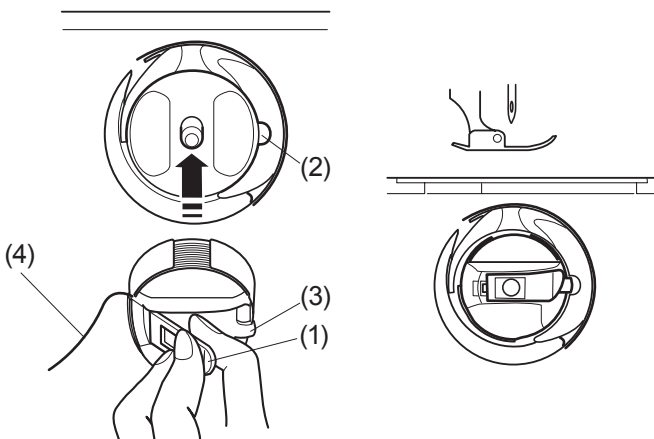

2.

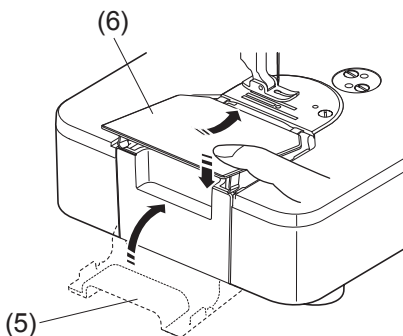

Inserting the Bobbin Case into the Hook



CAUTION:

Turn the power switch OFF before inserting the bobbin case.

*Be sure that the needle is at its highest position.

1. Holding the latch open, position the bobbin case into the hook aligning the slot with the rib. The bobbin case should lock into place when the latch is released.
 - (1) Latch
 - (2) Slot
 - (3) Rib

NOTE:

Leave a tail of the bobbin thread to the left as shown.
(4) Tail of bobbin thread

2. Close the hook cover and attach the hook cover plate in this order.
 - (5) Hook cover
 - (6) Hook cover plate

Threading the Needle Thread (for Leather, Heavy Fabric)

CAUTION:

Turn the power switch OFF before threading the machine.

- Synthetic thread sizes 20 to 30 are recommended. Do not use thread size 40 or finer. Otherwise, the thread may break.
- Use only left twist thread. Left twist thread will twist firmly when you twist it toward you with the fingers of your right hand.



1. Raise the presser foot lifter. Turn the power switch ON. Press the needle up/down button to raise the needle to its highest position. Turn the power switch OFF.
Set a spool of thread on the spool pin.
Pass the thread through the guide on the thread guide bar from behind.
(1) Guide
2. Pass the thread through the thread guide plate, then draw the thread between the pre-tension disks behind the pre-tension dial.
(2) Thread guide plate
(3) Pre-tension disks
(4) Pre-tension dial

*1 If the thread tends to twist too much, pass the thread through the 3 holes in the thread guide plate as shown in figure (A).
*2 For the standard setting of the pre-tension dial, the screw head (5) is sunk into the dial by about 4 mm (1/8" to 3/16").
(5) Screw head
(6) 4 mm (1/8" to 3/16")
3. Holding the thread with both hands, draw the thread down and around the tension dial from right to left. Pull the thread up to insert it between the tension disks and pass it over the tail of the check spring. Then pull the thread down over the loop of the check spring.
(7) Tension dial
(8) Tension disks
(9) Check spring
4. Draw the thread under the thread guide B. Pass the thread through the 2 holes in the thread guide C as shown.
(10) Thread guide B
(11) Thread guide C

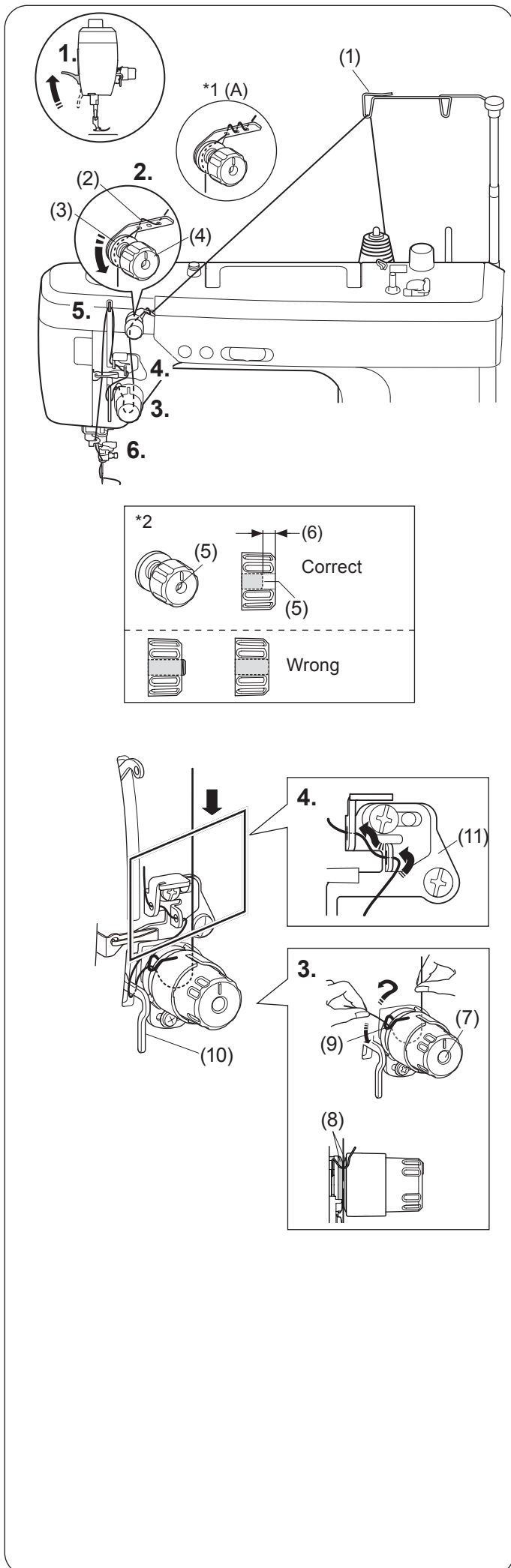

NOTE:

The needle thread tension can be adjusted with the thread guide C (refer to the next page).

5.

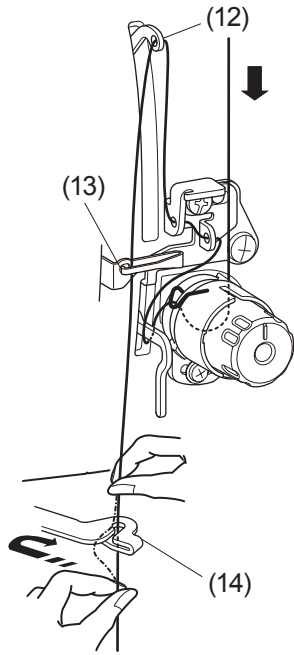

5. Draw the thread through the eye of the take-up lever. Pass the thread through the thread guide D. Holding the thread with both hands, slip the thread into the thread guide E as shown.

- (12) Eye of the take-up lever
- (13) Thread guide D
- (14) Thread guide E

6.

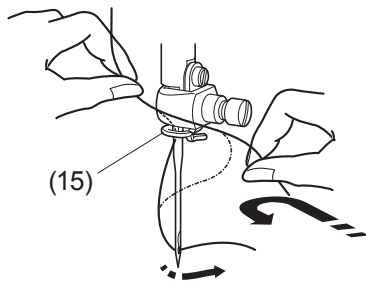

6. Draw the thread down to the needle bar thread guide, and thread the needle with the needle threader (refer to page 16).

- (15) Needle bar thread guide

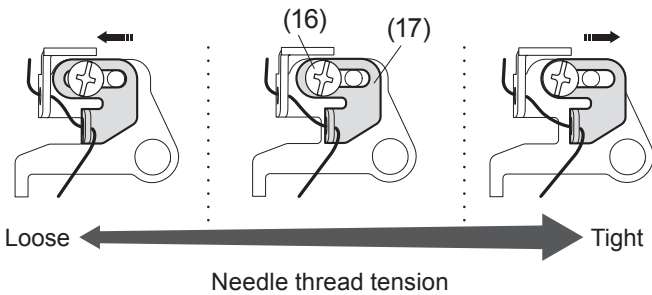

Adjusting the needle thread tension by the thread guide

Loosen the adjusting screw with the large screwdriver provided with the machine.

Slide the adjusting plate to the right or left to adjust the needle thread tension. Tighten the adjusting screw.

Needle thread tension should normally be adjusted with the thread tension dial (refer to "Adjusting Needle Thread Tension" on page 19).

- (16) Adjusting screw
- (17) Adjusting plate

Threading the Needle Thread (for medium and light fabric)

⚠ CAUTION:

Turn the power switch OFF before threading the machine.

Use only left twist thread. Left twist thread will twist firmly when you twist it toward you with the fingers of your right hand.



1. Raise the presser foot lifter. Turn the power switch ON.
Press the needle up/down button twice to raise the needle to its highest position.
Turn the power switch OFF.
Set a spool of thread on the spool pin.
Pass the thread through the guide on the thread guide bar from behind.

(1) Guide

2. Pass the thread through the thread guide plate, then draw the thread between the pre-tension disks behind the pre-tension dial.

(2) Guide plate

(3) Pre-tension disks

(4) Pre-tension dial

*1 If the thread tends to twist too much, pass the thread through the holes in the thread guide plate as shown in figure (A) or figure (B).

*2 For the standard setting of the pre-tension dial, the screw head (5) is sunk into the dial by about 4 mm (1/8" to 3/16").

(5) Screw head

(6) 4 mm (1/8" to 3/16")

3. Holding the thread with both hands, draw the thread down and around the tension dial from right to left. Pull the thread up to insert it between the tension disks and pass it over the tail of the check spring. Then pull the thread down over the loop of the check spring.

(7) Tension dial

(8) Tension disks

(9) Check spring

4. Draw the thread under the thread guide B and pass the thread through the thread guide D. Then draw the thread through the eye of the take-up lever.

(10) Thread guide B

(11) Thread guide D

(12) Eye of the take-up lever

NOTE:

When passing the thread through the eye of the thread take-up lever, make sure that the thread does not catch on the thread guide C.

(13) Thread guide C

5. Pass the thread through the thread guide D again. Holding the thread with both hands, slip the thread into the thread guide E as shown.

(14) Thread guide E

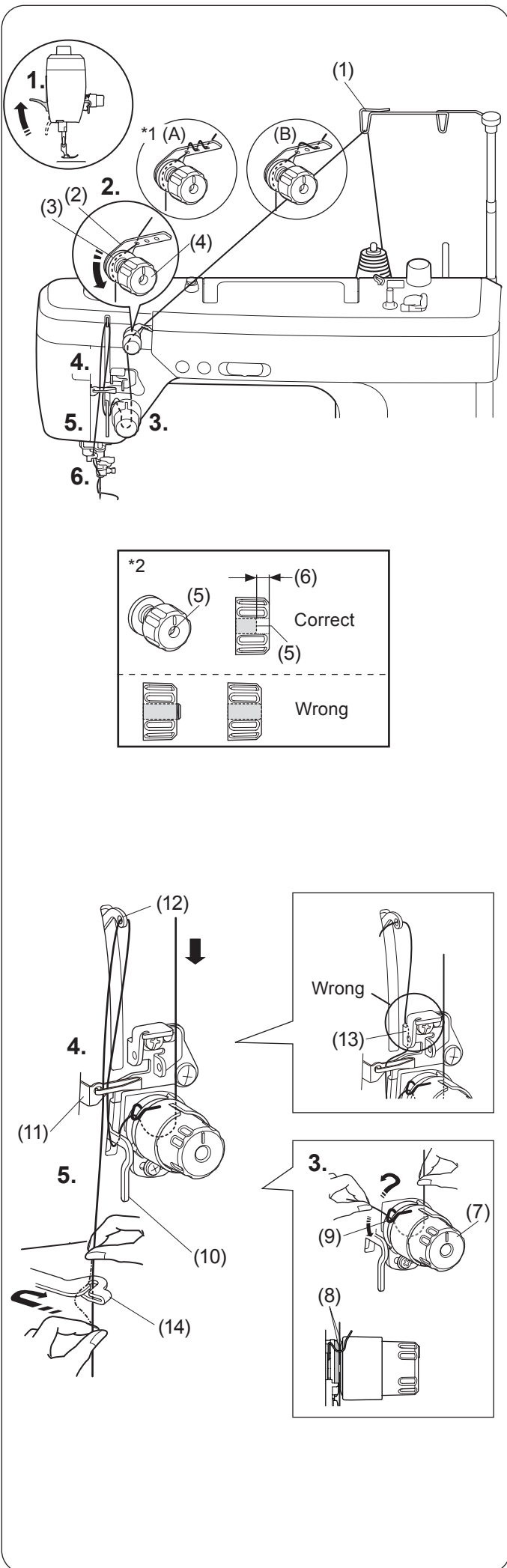

6.

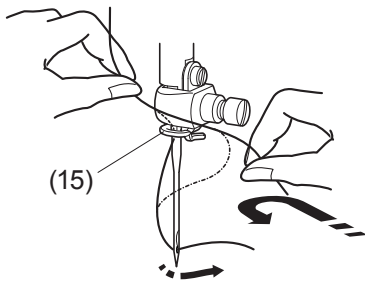

6. Draw the thread down to the needle bar thread guide, and thread the needle with the needle threader (refer to page 16).

(15) Needle bar thread guide

Example:

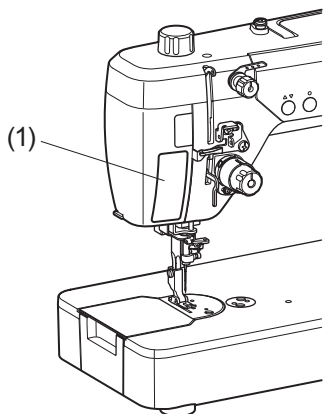

Threading guide sticker

There is a threading guide sticker in the standard accessories. If you wish, you can attach the sticker on the machine to check the threading procedure.

(1) Threading guide sticker

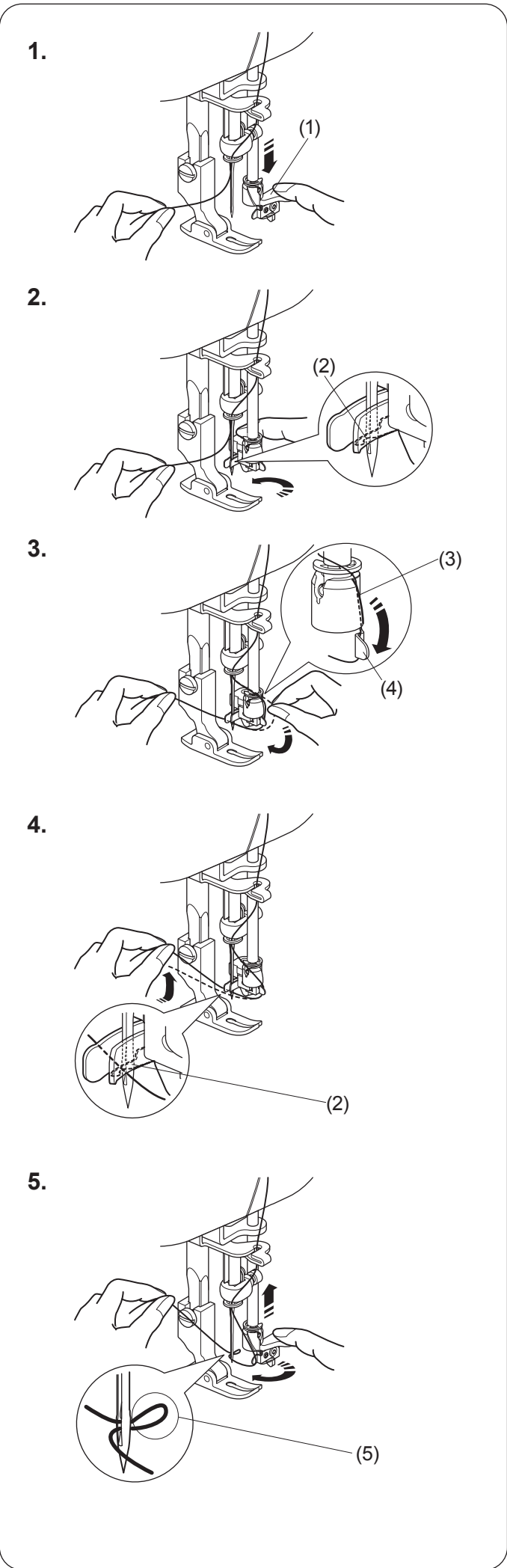

Built-in Needle Threader

1. Lower the presser foot. Press the needle up/down button twice to raise the needle to its highest position. Turn the power switch OFF.
Push the needle threader knob down as far as it will go.
(1) Knob

2. Turn the knob in the direction of the arrow to insert the hook into the needle eye.
The hook comes out through the needle eye as illustrated.
(2) Hook

3. Holding the thread with both hands, draw it along the thread path.
Then hook the thread around the guide.
(3) Thread path
(4) Guide

4. Draw the thread under the hook.
Hold the end of thread with your hand while pulling it up lightly in the direction of arrow.
(2) Hook

5. Turn the knob in the direction of the arrow as shown, drawing the thread loop through the needle.
Release the threader knob slowly. Then pull the thread loop to the right.
(5) Thread loop

The needle threader may not work well with these combinations.

Needle	Thread
#9	#20, #30, #50, #60
#11	#20, #30
#14	#16, #20, #30

1.

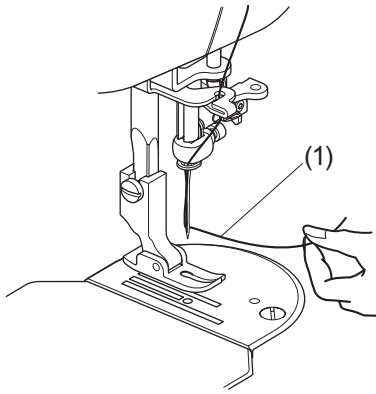

2.

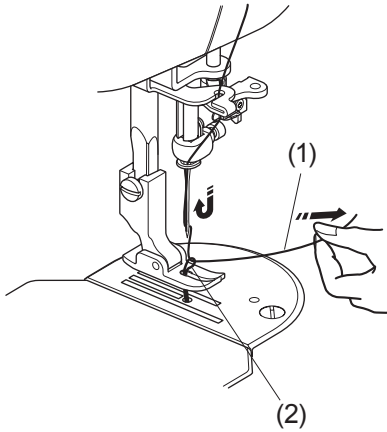

3.

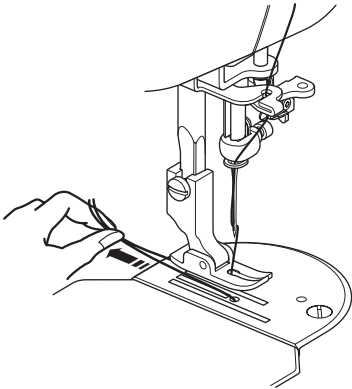

Drawing up the Bobbin Thread

1. Hold the needle thread lightly with your left hand.

(1) Needle thread

2. Turn the switch ON. Press the needle up/down button twice to pick up the bobbin thread.

Pull the needle thread to bring up a loop of bobbin thread.

(1) Needle thread

(2) Bobbin thread

3. Slide 10 cm (4") of both threads to the rear under the presser foot.

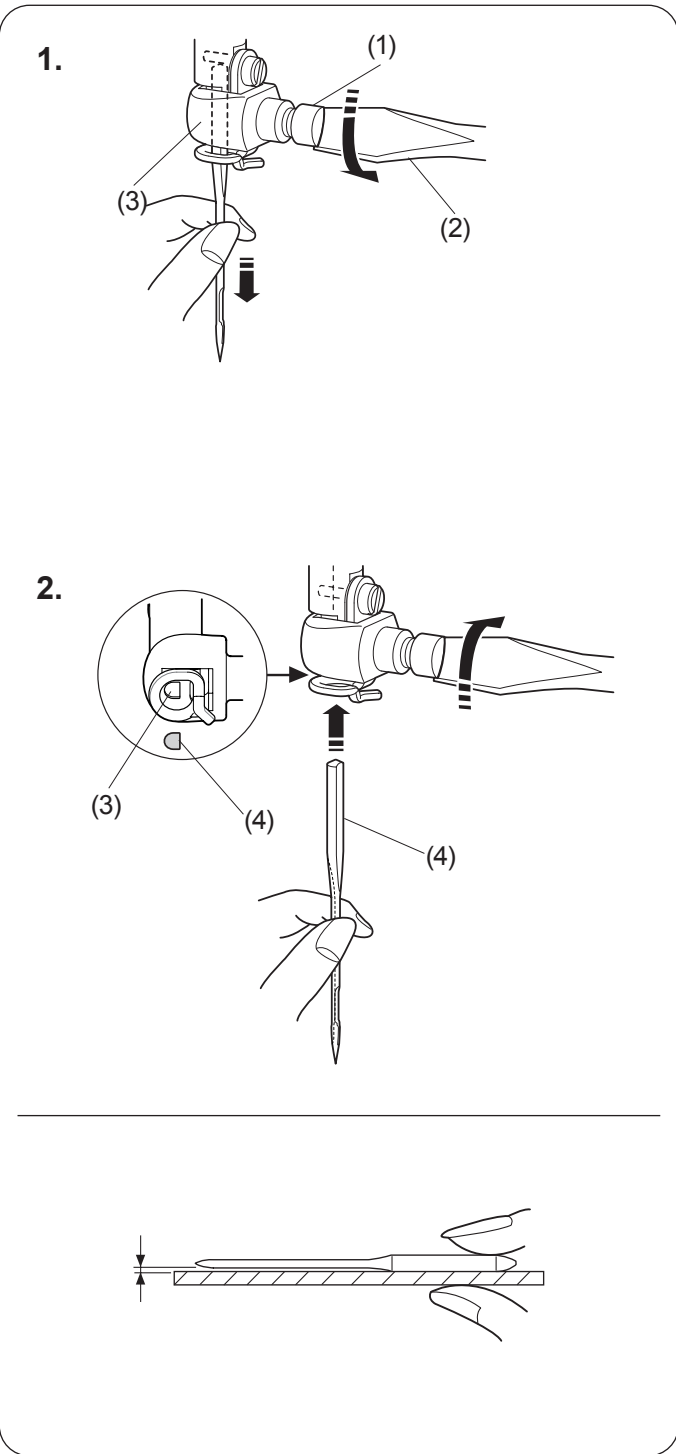

Changing the Needle

⚠ CAUTION:

Turn the power switch OFF and unplug the machine before changing the needle.

1. Lower the presser foot. Raise the needle. Turn the needle clamp screw counterclockwise with the large screwdriver.

Loosen the screw and remove the needle from the needle clamp.

- (1) Needle clamp screw
- (2) Screwdriver (large)
- (3) Needle clamp

2. Insert a new needle into the needle clamp with the flat side to the right, pushing it up as far as it will go.

Tighten the clamp screw firmly.

- (3) Needle clamp
- (4) Flat side

NOTE:

Use an HL x 5 needle.

To check the needle

To determine if the needle is defective, place the flat side of needle on something flat (a needle plate, piece of glass, etc.). The gap between the needle and the flat surface should be consistent.

Never use a bent or blunt needle, as it may cause skipped stitches or thread breakage. Defective needles can ruin the fabric. Be sure to use good quality needles. Change needles regularly.

Thread and Needle Chart

	Fabrics	Thread	Needle (HL x 5) size
Medium	Broadcloth Sheeting Gabardine Thin jersey	Synthetic #50-60 Cotton #50-60	#14
	Flannel Wool	Synthetic #50-60	#14
Heavy	Denim	Synthetic #20-50 Cotton #20-50	#14-18
	Jersey	Synthetic #20-50	#14-16
	Tweed	Synthetic #20-50 Cotton #30-50	#14-16
	Canvas	Synthetic #20-50	#14-18
	Artificial leather	Synthetic #20-30	#14-18

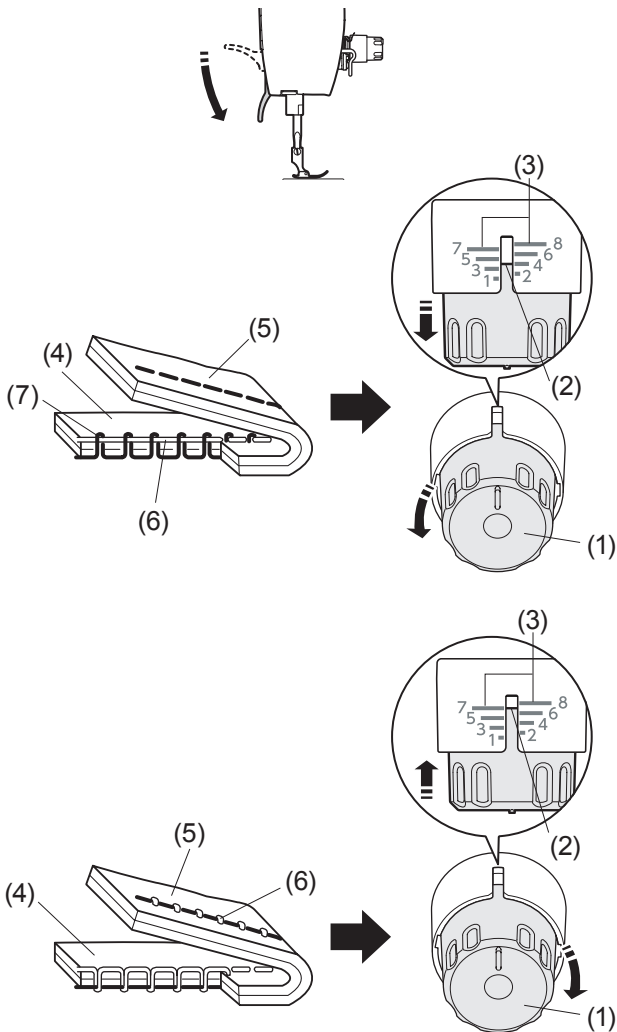
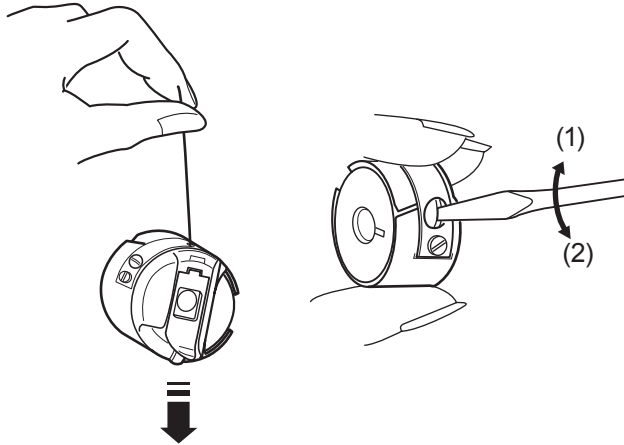
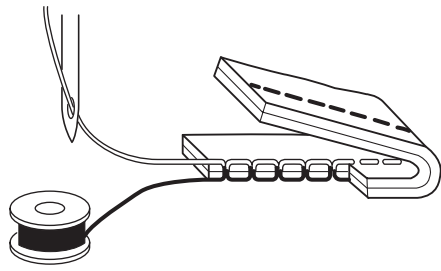

Balancing Needle Thread Tension

The needle thread and bobbin thread should interlock at the center of two layers of the fabric in straight seams.

Adjusting Bobbin Thread Tension

Test the bobbin thread tension by holding the end of the bobbin thread and suspending the bobbin case as illustrated. Then jerk the bobbin case once by flicking your wrist.

If the thread comes out of the bobbin case continuously, and the bobbin case keeps falling, the bobbin thread tension is too loose.

Make a slight adjustment by turning the screw clockwise with the small screwdriver.

(1) To tighten

If the thread does not come out of the bobbin case at all, the bobbin thread tension is too tight.

Make a slight adjustment by turning the screw counterclockwise with the small screwdriver.

(2) To loosen

Adjusting Needle Thread Tension

Needle thread tension is too tight:

Lower the presser foot before adjusting the needle thread tension.

If the bobbin thread shows through on the right side of the fabric and it feels bumpy, loosen the needle thread tension by turning the dial to the left. Adjust the edge of the dial to a smaller indicator line number.

- (1) Tension dial
- (2) Edge of the dial
- (3) Indicator lines
- (4) Right side of the fabric
- (5) Wrong side of the fabric
- (6) Needle thread
- (7) Bobbin thread

Needle thread tension is too loose:

Lower the presser foot before adjusting the needle thread tension.

If the needle thread loops on the wrong side of the fabric, tighten the needle thread tension by turning the dial to the right. Adjust the edge of the dial to a larger indicator line number.

- (1) Tension dial
- (2) Edge of the dial
- (3) Indicator lines
- (4) Right side of the fabric
- (5) Wrong side of the fabric
- (6) Needle thread

HOW TO SEW

Test Stitching

NOTE:

Raise the thread take-up lever to its highest position, otherwise the needle thread may slip out from the needle eye.

(1) Thread take-up lever

Before you start sewing, try test stitching with the same thread and fabric as you plan to use for actual sewing.

1. Turn the stitch length adjustment dial to adjust the stitch length.
Slide the needle and bobbin threads to the back under the presser foot. Use the same fabric as you plan to use for actual sewing.

(2) Stitch length adjustment dial

2. Turn the handwheel toward you to lower the needle into the fabric.

(3) Handwheel

3. Set the speed control slider to the leftmost position (slow: ►) until you get used to the sewing speed.

Lower the presser foot lifter.

Press the foot control to start sewing.

(4) Presser foot lifter

(5) Foot control

NOTE:

The machine will not run if the presser foot is in the up position.

4. Check the sewing results and adjust the needle thread tension as necessary.

(6) Thread tension dial

5. Press the auto thread cutter button to trim the threads.
You can continue sewing without pulling the bobbin thread up to the needle plate after trimming the threads.

(7) Auto thread cutter button

NOTE:

Use the thread cutter on the face cover if the thread is thicker than #30.

(8) Thread cutter

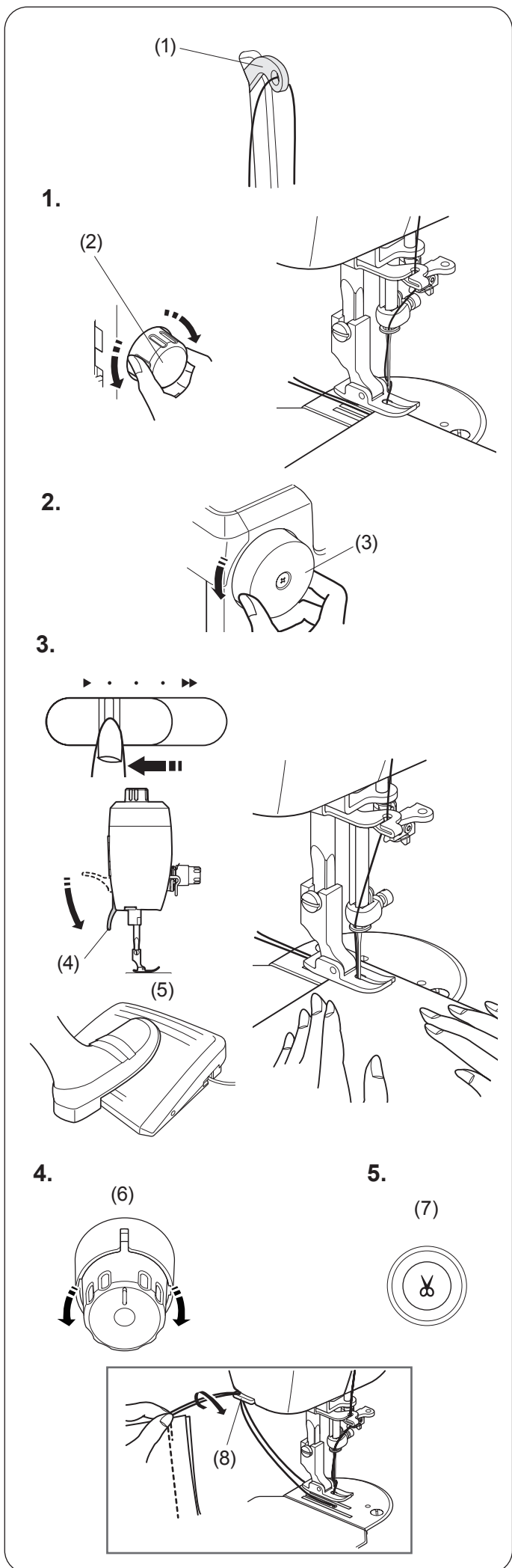

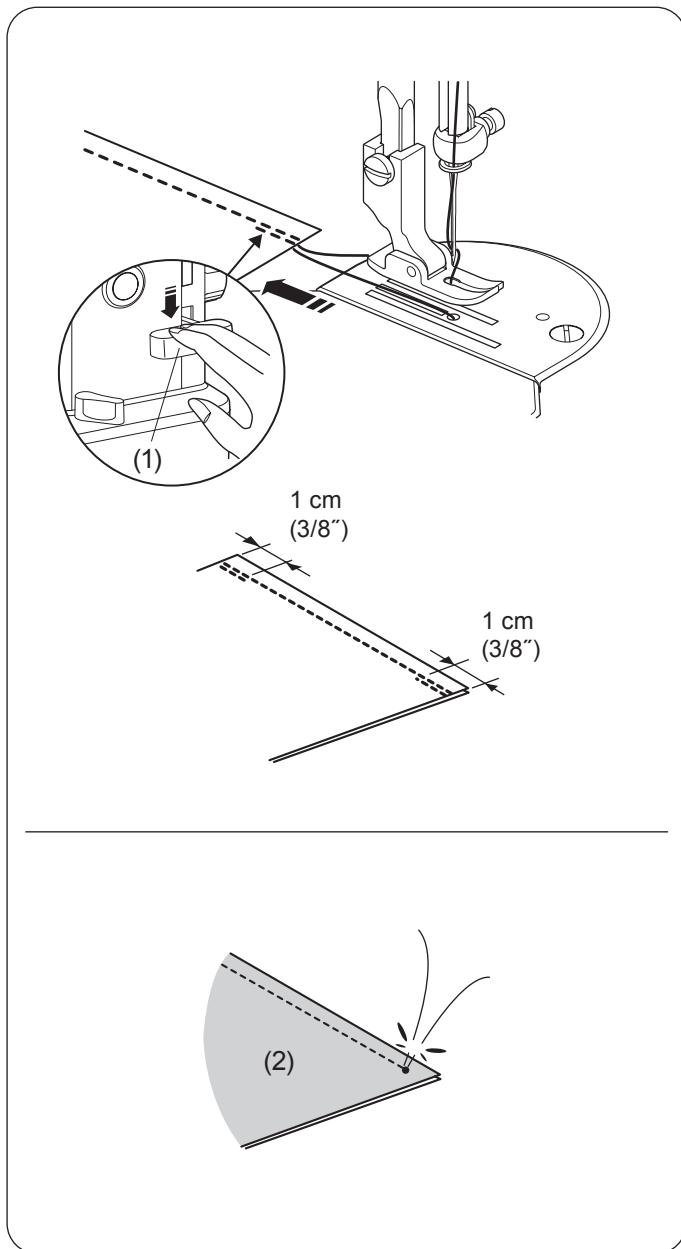

Securing a Seam

By reverse stitching

The machine will sew in reverse as long as the reverse stitch lever is pressed.

Secure the beginning and end of a seam by sewing in reverse for about 1 cm (3/8").

- (1) Reverse stitch lever

NOTE:

Reverse stitching on heavy fabric should be done at a slow speed.

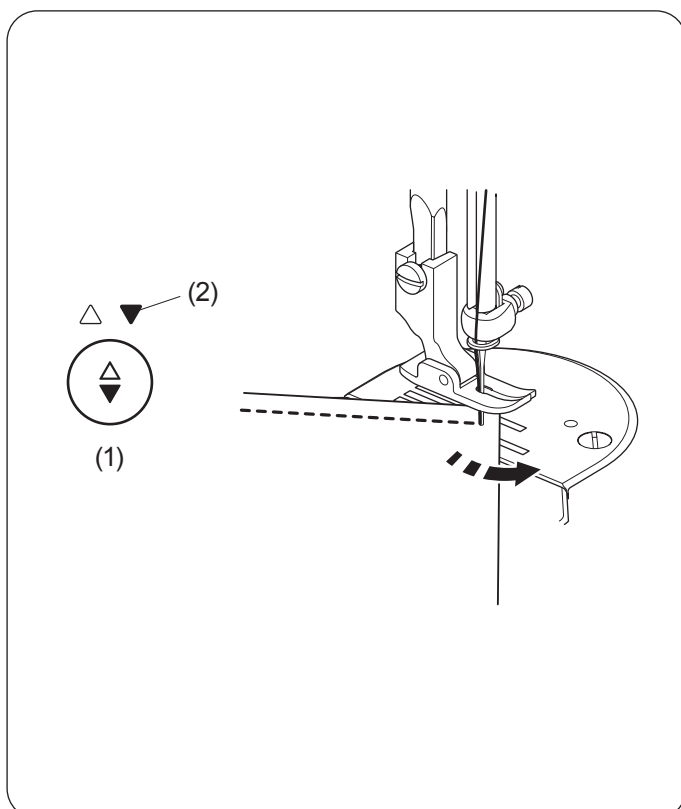

By knotting the threads

Pull the bobbin thread to bring the needle thread to the wrong side of fabric.

Tie the threads together. Trim the remaining threads.

- (2) Wrong side of fabric

Turning a Square Corner

Stop the machine a few stitches before the end of the seam.

Press the needle up/down button a few times until the needle falls on the end of the seam.

Each time you press the needle up/down button, the LED lights alternate between left and right (red and blue), allowing you to change the needle stop position when the machine is stopped (refer to page 6).

- (1) Needle up/down button
- (2) LED light

Raise the presser foot.

Pivot the fabric around the needle to change the sewing direction.

Lower the presser foot and start sewing in a new direction.

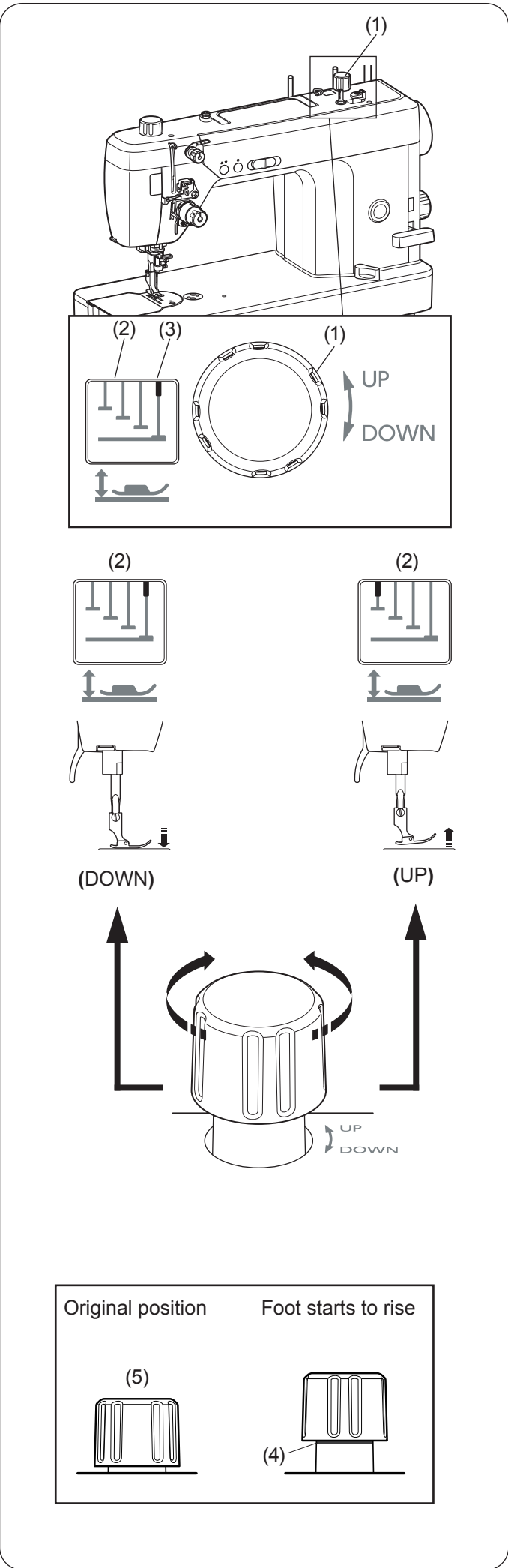

Floating Dial

You can decrease layer slippage and wrinkles by lifting the presser foot up slightly with the floating dial. You can check the presser foot height on the presser foot height indicator.

- (1) Floating dial
- (2) Presser foot height indicator
- (3) Red mark

Turn the floating dial counterclockwise (toward "UP") to raise the presser foot. The red mark on the presser foot height indicator moves to the left.

Turn the floating dial clockwise (toward "DOWN") to lower the presser foot. The red mark on the presser foot height indicator moves to the right.

- (2) Presser foot height indicator

NOTE:

- When turning the floating dial, the presser foot height will not increase unless you continue turning the floating dial numerous times.
- When you see a line on the base of the dial, the presser foot will start to rise.

- (4) Line

- When using the floating dial, always adjust the presser foot height and conduct a test sew on a scrap piece of fabric before actual sewing.
- When not using the floating function, turn the floating dial clockwise (toward "DOWN") until the dial stops to return the foot to its original position.

- (5) Original position

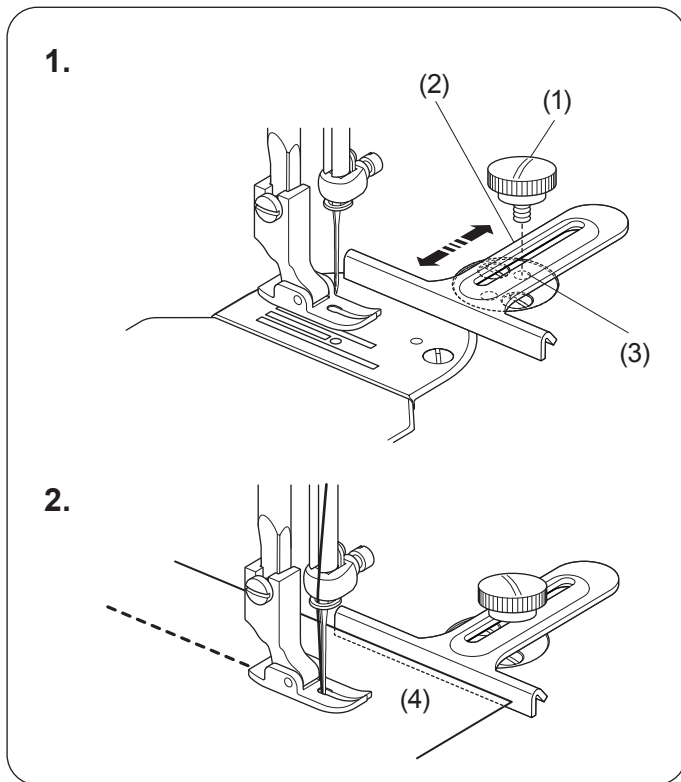

Using the Cloth Guide

⚠ CAUTION:

Turn the power switch OFF and unplug the machine before attaching or removing the cloth guide.

1. Attach the cloth guide to the hole for attachments with the thumbscrew.

Adjust the position of the cloth guide to the desired position and tighten the thumbscrew.

- (1) Thumbscrew
- (2) Cloth guide
- (3) Hole for attachments

2. Place the fabric with its edge against the cloth guide and sew.

- (4) Cloth edge

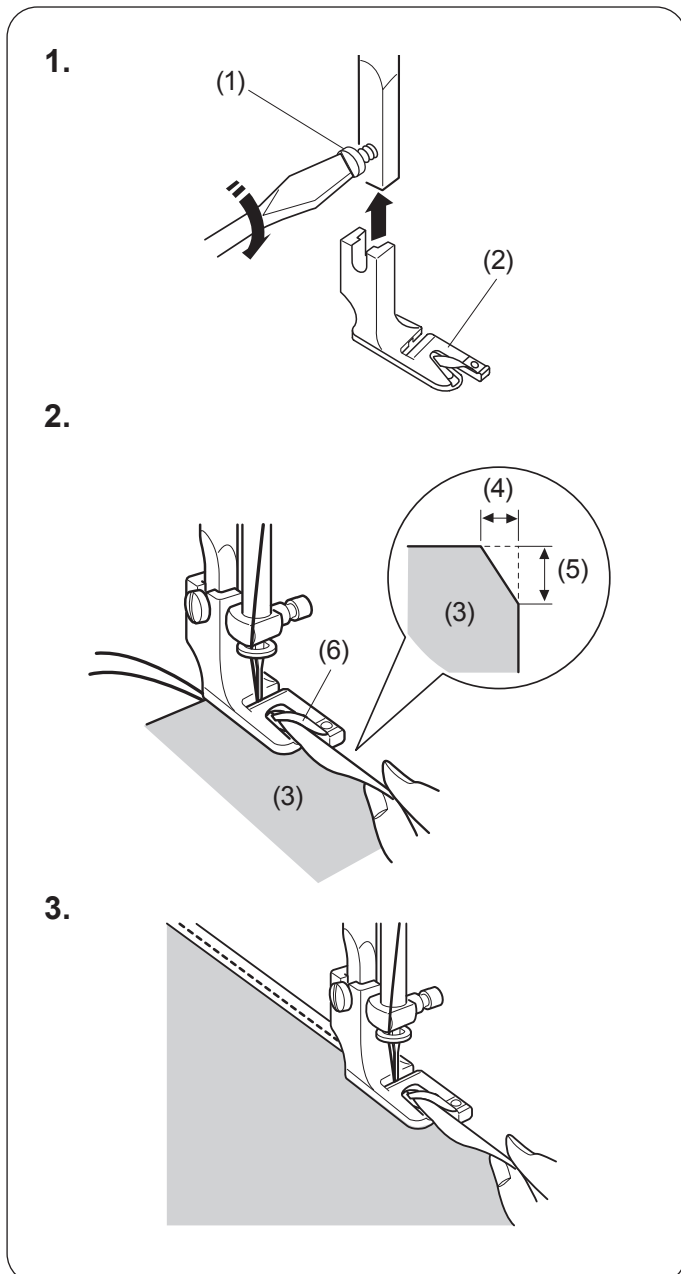

Rolled Hem

⚠ CAUTION:

Turn the power switch OFF and unplug the machine before changing the foot.

1. Attach the hemmer foot to the presser foot bar. Tighten the setscrew using the large screwdriver.

- (1) Setscrew
- (2) Hemmer foot

2. Fold the edge of the fabric twice, 6 cm (2 3/8") in length and 0.3 cm (1/8") in width.

Trim the corner 0.5 cm (3/16") by 0.8 cm (1/4") for easier insertion of the hem into the foot.

Position the fabric aligning the edge of hem with the curl of the foot.

- (3) Wrong side of the fabric
- (4) 0.5 cm (3/16")
- (5) 0.8 cm (1/4")
- (6) Curl of the foot

3. Lower the foot and sew approximately 1-2 cm (1/2"-1") while pulling both threads to the back.

Stop the machine and lower the needle into the fabric. Raise the foot and insert the folded portion of the fabric into the curl of the foot.

Lower the foot, and then sew while lifting up the edge of the fabric to keep it feeding smoothly and evenly.

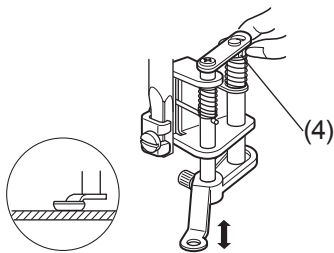
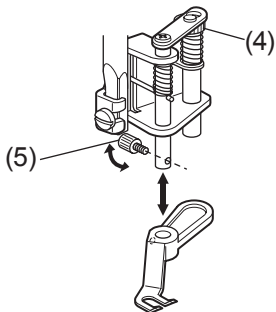
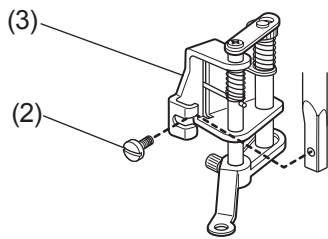
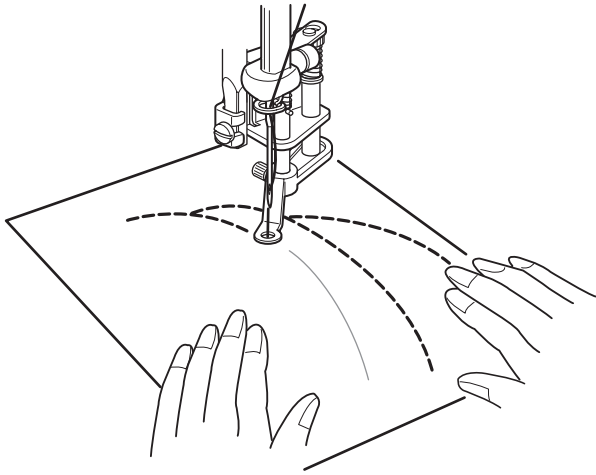
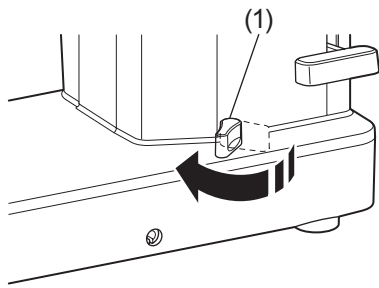

Free motion quilting

Before sewing free motion quilting, move the drop feed lever to the left to drop the feed dogs.

- (1) Drop feed lever

! CAUTION:

Turn the power switch OFF and unplug the machine before changing the foot or foot holder.

Attaching the free motion quilting foot holder

Remove the presser foot (refer to page 8), and attach the setscrew and the free motion quilting foot holder. Make sure that the needle enters the center of the hole in the foot.

- (2) Setscrew
- (3) Free motion quilting foot holder

Changing the foot

Raise the presser foot lifter and turn the round nut to bring the foot to the lowest position. Remove the setscrew and remove the foot. Attach the desired foot and secure it with the setscrew.

- (4) Round nut
- (5) Setscrew

This product includes the closed-toe foot and open-toe foot.

- (6) Closed-toe foot
- (7) Open-toe foot

Adjusting the height of the foot

Lower the presser foot lifter. Adjust the height of the foot by turning the round nut until the bottom of the foot barely touches the top of the quilt layers.

- (4) Round nut

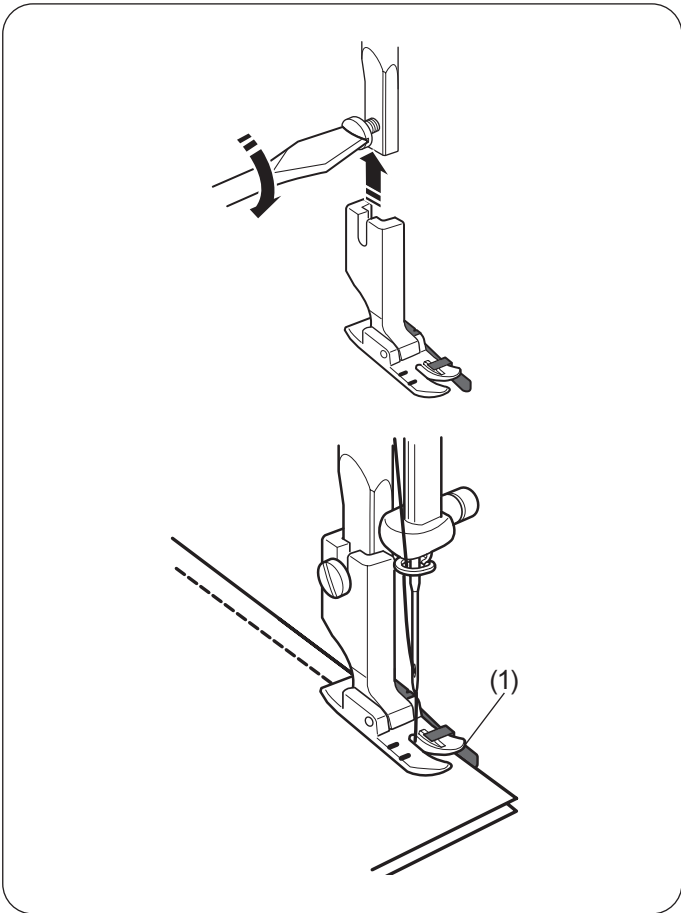

Quilt Piecing

⚠ CAUTION:

Turn the power switch OFF and unplug the machine before changing the foot.

You can sew a 1/4" (0.65 cm) seam allowance from the edge of the fabric with the quilting foot. Attach the quilting foot to the presser bar. Tighten the setscrew firmly with the screwdriver.

Place the patchwork pieces right sides together. Sew while guiding the edge of fabric along the guide.

(1) Guide

⚠ CAUTION:

Be careful not to press more than 1/4" (0.65 cm) of excess fabric against the guide.

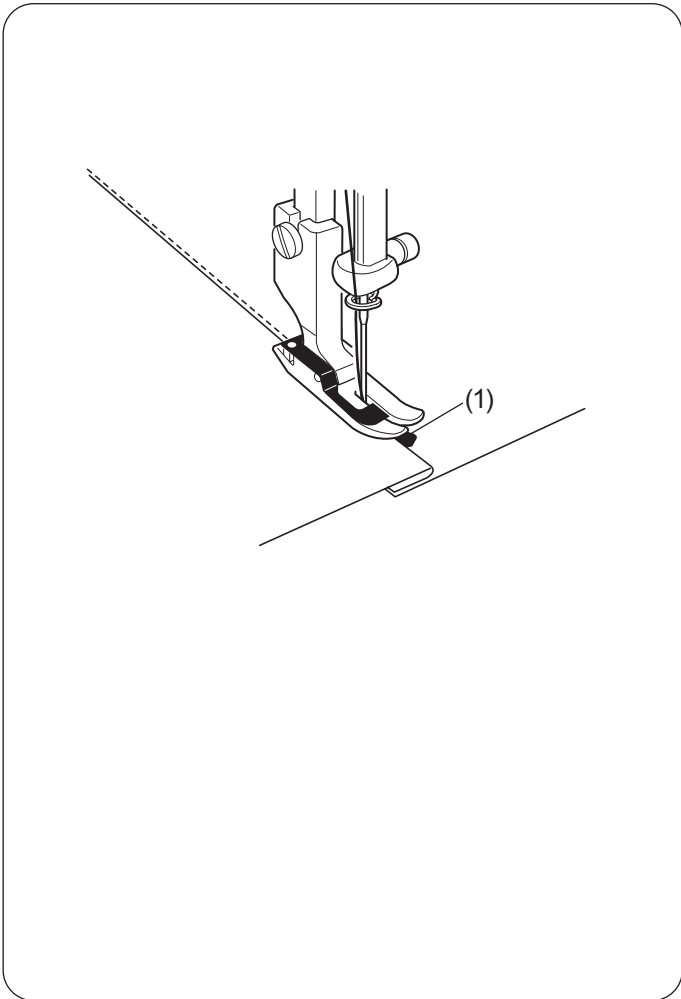

Ditch Quilting

⚠ CAUTION:

Turn the power switch OFF and unplug the machine before changing the foot.

Attach the ditch quilting foot to the presser bar. Open the right side of the fabrics after straight stitch sewing. Place the presser foot guide along the folded edge and sew straight stitches.

(1) Guide

1. 2.

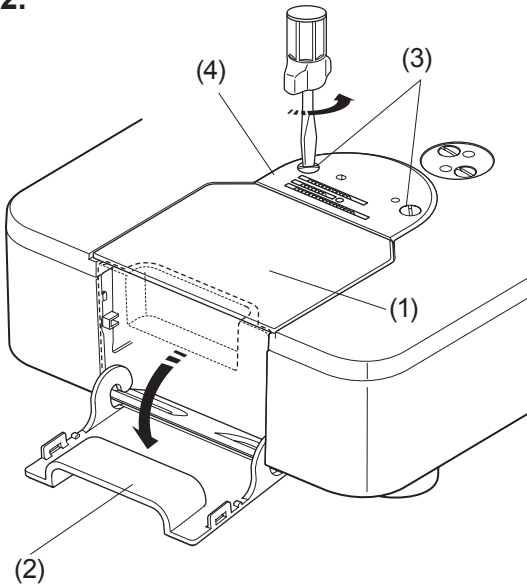

3.

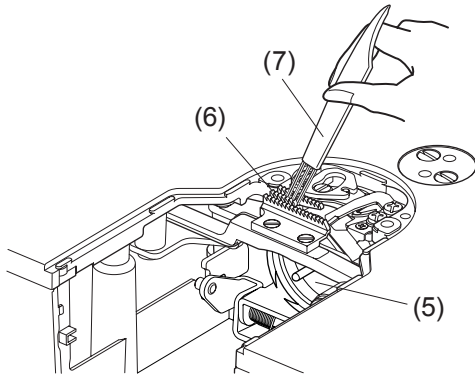

CARE & MAINTENANCE

Cleaning the Hook and Feed Dogs

CAUTION:

- Turn the power switch OFF and unplug the machine before cleaning.
- Do not dismantle the machine in any way other than as explained in this section.

Remove the needle and presser foot (refer to pages 8 and 18).

1. Remove the hook cover plate and open the hook cover (refer to page 9).
 2. Loosen the setscrews and remove the needle plate.
 3. Clean the hook race and feed dogs with a lint brush.
- After cleaning the machine, attach the needle plate, needle, presser foot and hook cover plate.

- (1) Hook cover plate
- (2) Hook cover
- (3) Setscrew
- (4) Needle plate
- (5) Hook race
- (6) Feed dogs
- (7) Lint brush

Oiling the Machine

CAUTION:

- Turn the power switch OFF and unplug the machine before oiling.
- Do not apply oil to the bobbin winder spindle. There are electrical components under the bobbin winder spindle, so this may cause a malfunction.

- (1) Bobbin winder spindle

Oil the points shown to the left (A, B, C and D) with two or three drops of oil.

Oil the machine once a day if you use it frequently.

Use a soft, dry cloth to remove excess oil.

Remove the bobbin case from the hook race when you oil the hook race.

After oiling, stitch on a piece of waste fabric to absorb excess oil.

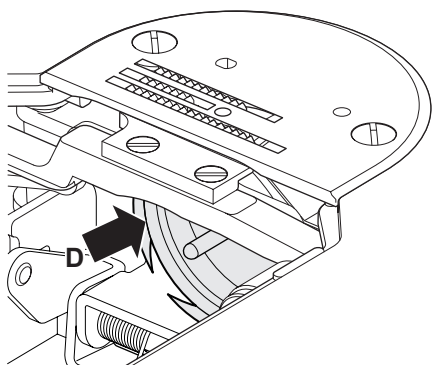
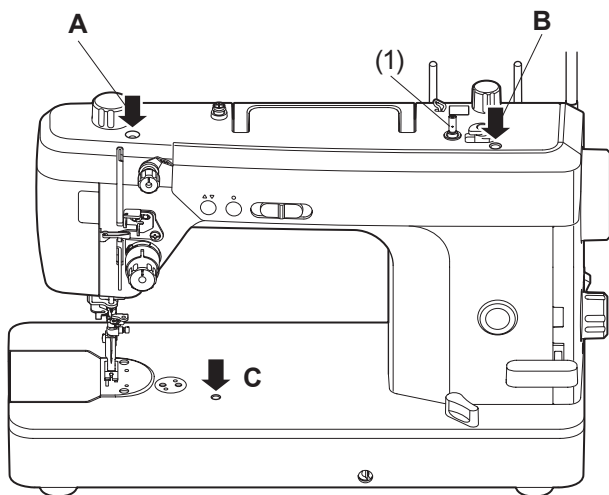

Troubleshooting

Condition	Cause	Reference
The needle thread breaks.	<ol style="list-style-type: none"> 1. The needle thread is not threaded properly. 2. The needle thread tension is too tight or too weak. 3. The needle is bent or blunt. 4. The needle is incorrectly inserted. 5. The needle thread and the bobbin thread are not set under the presser foot when starting sewing. 6. Thread is caught in the hook race. 7. The thread is either too heavy or too fine for the needle. 	<p>See pages 12, 14 See pages 13, 19 See page 18 See page 18 See page 17</p> <p>See page 26 See page 18</p>
The bobbin thread breaks.	<ol style="list-style-type: none"> 1. The bobbin thread is not threaded properly in the bobbin case. 2. Thread is caught in the hook race. 3. The bobbin thread tension is too tight. 	<p>See page 11 See page 26 See page 11, 19</p>
The needle breaks.	<ol style="list-style-type: none"> 1. The needle is incorrectly inserted or bent. 2. The needle clamp screw is loose. 3. The needle is too fine for the fabric being used. 4. The fabric is being pushed or pulled. 	<p>See page 18 See page 18 See page 18 See page 20</p>
Skipped stitches	<ol style="list-style-type: none"> 1. The needle is incorrectly inserted, bent or blunt. 2. The needle and/or fabrics are not suitable for the work being sewn. 3. The needle or bobbin thread is not threaded properly. 4. A poor quality needle is being used. 	<p>See page 18 See page 18 See pages 11, 12, 14 Change the needle.</p>
Seam puckering	<ol style="list-style-type: none"> 1. The needle thread tension is too tight. 2. The needle or bobbin thread is not threaded properly. 3. The needle is not suitable for the fabric being sewn. 4. The stitch length is too long for the fabric. 5. The presser foot pressure is not appropriate. 	<p>See pages 13, 19 See pages 11, 12, 14 See page 18 Make the stitch shorter. See page 7</p>
The fabric is not feeding smoothly.	<ol style="list-style-type: none"> 1. The feed dogs are packed with lint. 2. The stitches are too fine. 3. The presser foot pressure is weak. 	<p>See page 26 Make the stitch longer. See page 7</p>
Stitches form loops below the fabric.	<ol style="list-style-type: none"> 1. The needle thread tension is too weak. 2. The needle is either too heavy or too fine for the thread. 	<p>See pages 13, 19 See page 18</p>
The machine does not work.	<ol style="list-style-type: none"> 1. The machine is not plugged in. 2. Thread is caught in the hook race. 3. The presser foot is raised. 4. The machine motor is malfunctioning. 	<p>See page 5 See page 26 See page 7 Contact the service center or the store from whom the machine was purchased.</p>
The machine does not run smoothly and is noisy.	<ol style="list-style-type: none"> 1. Thread is caught in the hook race. 2. Lint has built up in the hook race or bobbin case. 3. The machine needs oiling. 	<p>See page 26 See page 26 See page 26</p>
The thread cutter does not cut the thread when the thread cutter button is pressed.	<ol style="list-style-type: none"> 1. The needle is not correctly inserted or bent. 2. Lint has built up in the hook race. 3. The needle thread is not threaded properly. 	<p>See page 18 See page 26 See pages 12, 14</p>

*It is not abnormal for a faint humming sound to be heard from the internal motors.

EC DECLARATION OF CONFORMITY

Manufacturer: JANOME Corporation

Address: 1463 Hazama-machi, Hachioji, Tokyo 193-0941, Japan

This machine complies with the following regulations:

IEC 60335-1: 2020 and EN IEC 60335-1: 2023 + A11: 2023

IEC 60335-2-28: 2021 and EN IEC 60335-2-28: 2025 + A11: 2025

EN 62233: 2028

EN IEC 55014-1: 2021

EN 55014-2: 2021

EN IEC 61000-3-2: 2019 + A1 + A2

EN 61000-3-3: 2013 + A1 + A2

This page is left intentionally blank.

